

# MAXI-PUNCH

TN OR TiCN COATED PUNCHES  
CAN GIVE YOU UP TO SEVEN TIMES  
NORMAL LIFE EXPECTANCY OF STANDARD TOOLING



**AUSTRALIA'S LEADING  
PRECISION TOOL MANUFACTURER**

# CONTENTS

## FM TOOLING

**Page No.**

'A' Station Easy Adjustment Tooling.....	1
'B' Station Easy Adjustment Tooling.....	2
'B' Station Heavy Duty Tooling—Punching Unit .....	3
'B' Station Heavy Duty Tooling—Nibbling Unit .....	4
'C' Station Punching, Parting & Notching Assembly.....	5
'D' Station Punching, Parting & Notching Assembly.....	6
'E' Station Punching, Parting & Notching Assembly.....	7
'C', 'D' & 'E' Station Parting Tool Systems.....	8
'D' Station High Performance Parting Tools .....	9
'E' Station High Performance Parting Tools .....	10
High Precision Line Up Tools / Adaptor Sleeves .....	11

## AMADA STYLE TOOLING

'A' Station Tooling .....	13
'B' Station Tooling .....	14
'C' Station Tooling.....	15
'C' Station Push Button & Standard Guide Assemblies.....	16
'D' Station Tooling.....	17
'D' Station Push Button & Standard Guide Assemblies.....	18
'E' Station Tooling .....	19
'E' Station Push Button & Standard Guide Assemblies.....	20

## WILSON STYLE TOOLING

20' Station Multi Tools.....	22
'A' Station Series 90 Tooling & Assemblies.....	23
'B' Station Series 90 Tooling & Assemblies.....	24
'C', 'D' & 'E' Station Series 90 Tooling .....	25
'C', 'D' & 'E' Station Series 90 Push Button Adjustable Guide Assemblies.....	26
'A' Station Series 80 Tooling.....	27
'B' Station Series 80 Tooling .....	28
'C', 'D' & 'E' Station Series 80 Tooling.....	29

## MATE ULTRA STYLE TOOLING

'A' & 'B' Station Adjustable Spigot Punch, Die & Stripper Sets .....	31
'C', 'D' & 'E' Station Tooling .....	32
20', 10' & 6' Station Multi Tools .....	33

## SPECIAL SHAPES & TECHNICAL INFORMATION

Category A, B & C Shapes .....	35, 36, 37, 38
Technical Information.....	39, 40
Handy Hints .....	41

# F M

# Tooling

*Manufactured by*

**F.M. TOOL & GAUGE PTY. LTD.**

A.B.N. 91 008 262 520

CUDLEE CREEK, SOUTH AUSTRALIA, 5232

PH. (08) 8389 2272 FAX. (08) 8389 2309 or (08) 8389 2478

Free Call 1800 882 993 E-mail - [sales@fmtool.com.au](mailto:sales@fmtool.com.au)

[www.fmtool.com.au](http://www.fmtool.com.au)



# FM TOOL

## 'A' STATION E.A. TOOLING

(Easy Adjustment)  
( up to ½" or 12.7mm dia )

### USES STANDARD AMADA STYLE 'A' STATION PUNCHES

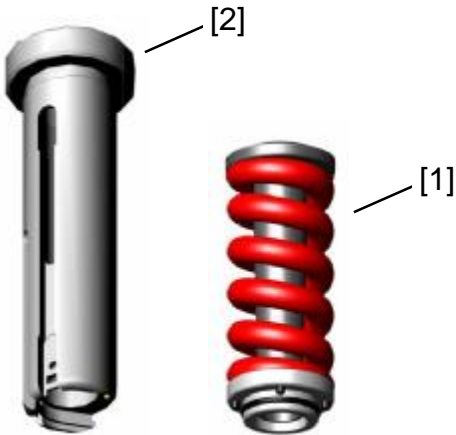

[1] Spring Pack (complete)..... EA180-000

[2] Open Guide..... AA182-001  
(keyed @ 0, 135, 225 deg)

[2] Open Guide..... AA182-002  
(keyed @ 0, 90, 180, 270 deg)

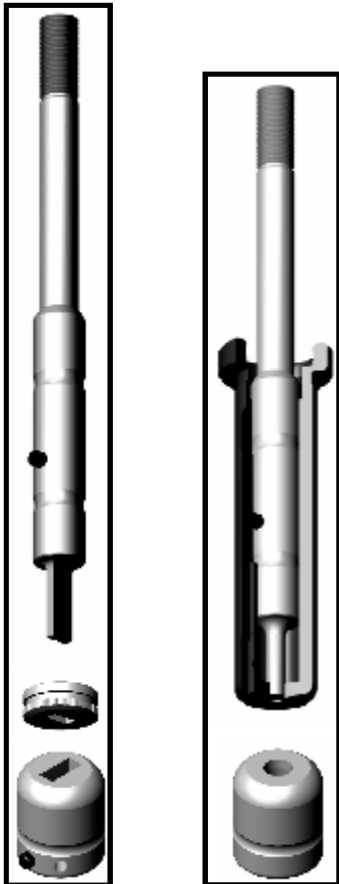

[3]

[4]

### [3]

Punch, Die & Str. Set Round..... EA100-000  
(used with open guides [2] )

Punch, Die & Str. Set Shaped ..... EA100-XXX  
(used with open guides [2] )

Stripper Button Round/Shaped ..... AA185-000/XXX

Punch Only Round/Shaped..... AA101-000/XXX

Die Round..... AA206-000

Die Shaped ..... AA106-XXX

### [4]

Punch, Die & Guide Set Round..... EA110-000

Punch, Die & Guide Set Shaped ..... EA110-XXX

Guide Only Round/Shaped ..... AA112-000/XXX

Punch Only Round/Shaped..... AA101-000/XXX

Die Round..... AA206-000

Die Shaped ..... AA106-XXX

Die Shims ea..... AA206-SHIM(0.5,1.0 & 1.5mm)

For **PRICING** and extended description of the tooling on this page log on to our web site at

[www.fmtool.com.au](http://www.fmtool.com.au)

Select **TOOLING**; then under Product Group **THICK TURRET**, select **"EA", Parting & 'HD' Tooling (FM)**, choose your A' St EA requirements listed under section **AA0.11A**

Pricing and description for all shapes, rounds and accessories for Thick Turret Tooling is available at this site

**'B' STATION E.A. TOOLING**

(Easy Adjustment)

( up to 1 ¼" or 31.75mm dia )

**USES STANDARD AMADA STYLE  
'B' STATION PUNCHES**

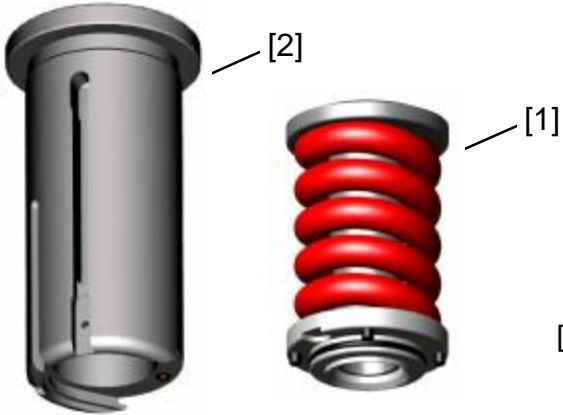

[1] Spring Pack (complete)..... EA380-000

[2] Open Guide ..... AA382-001  
(keyed @ 0, 45, 90, 135 deg)

[2] Open Guide ..... AA382-002  
(keyed @ 0, 90, 180, 270 deg)

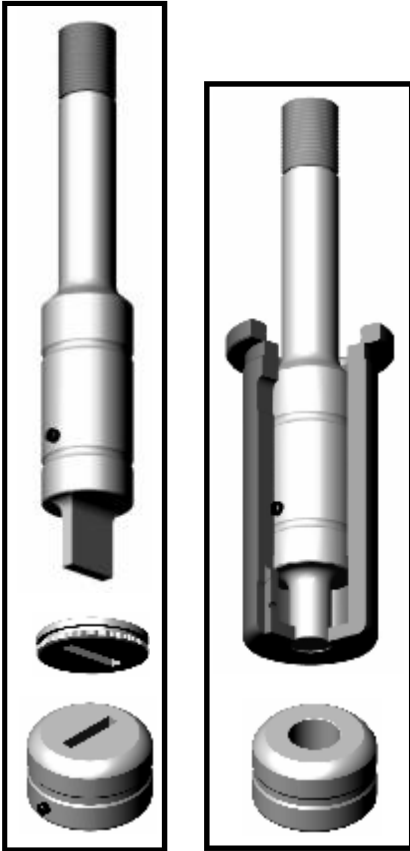

[3]

[4]

**[3]**

Punch, Die & Str. Set Round..... EA300-000  
(used with open guides [2] )

Punch, Die & Str. Set Shaped..... EA300-XXX  
(used with open guides [2] )

Stripper Button Round/Shaped ..... AA385-000/XXX

Punch Only Round/Shaped..... AA301-000/XXX

Die Round..... AA406-000

Die Shaped..... AA306-XXX

**[4]**

Punch, Die & Guide Set Round..... EA310-000

Punch, Die & Guide Set Shaped..... EA310-XXX

Guide Only Round/Shaped ..... AW302-000/XXX

Punch Only Round/Shaped..... AA301-000/XXX

Die Round..... AA406-000

Die Shaped..... AA306-XXX

Die Shims ea. .... AA406-SHIM(0.5,1.0 & 1.5mm)

For **PRICING** and extended description of the tooling on this page log on to our web site at

**[www.fmtool.com.au](http://www.fmtool.com.au)**

Select **TOOLING**; then under Product Group **THICK TURRET**, select **"EA"**, Parting & 'HD' Tooling (FM) , choose your B' St EA requirements listed under section **AA0.11B**

Pricing and description for all shapes, rounds and accessories for Thick Turret Tooling is available at this site

## 'B' STATION HEAVY DUTY PUNCHING TOOLS ( up to 1 ¼" or 31.75mm dia )

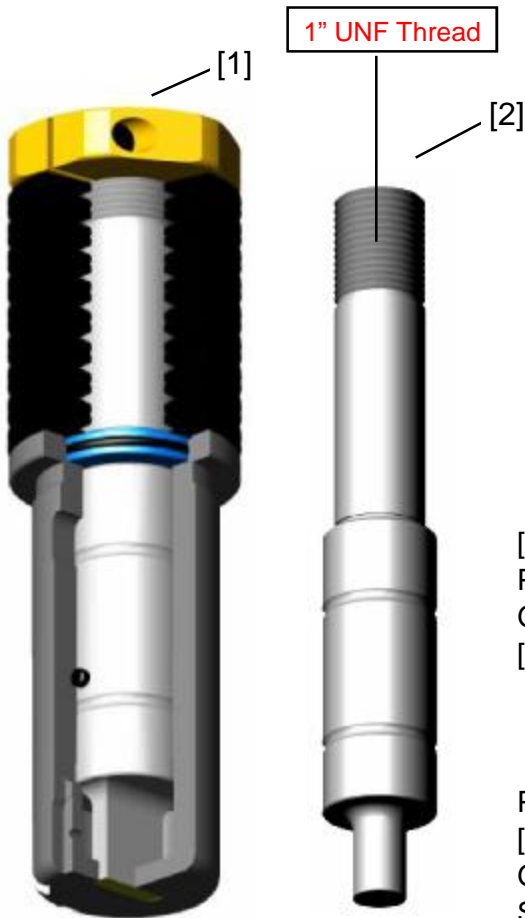

**High speed stripping & extra punch travel for punching heavy gauge material**

### Shapes

[1] Punch & Guide Assembly.....	AW360-XXX
Punch Only .....	AW301-XXX
Guide Only (hardened) .....	AW322-XXX
[3] Solid Precision Die.....	AA306-XXXHD

### Rounds

Punch & Guide Assembly.....	AW360-000
[2] Punch Only .....	AW401-000
Guide Only (hardened) .....	AW422-000
Solid Precision Die.....	AA406-000HD

### Assembly Parts

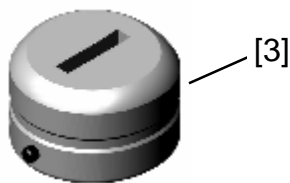

Super Locking Head.....	AW414-000H
Disc Spring ea (18 required) .....	AW463-000
0mm Punch Shim Collar (for new punch) .	AW464-NEW
1mm Punch Shim Collar.....	AW464-1MM
2mm Punch Shim Collar.....	AW464-2MM
3mm Punch Shim Collar.....	AW464-3MM
O'Rings for Collars.....	AA415-001

Die Shims ea..... AA406-SHIM(0.5,1.0 & 1.5mm)

For **PRICING** and extended description of the tooling on this page log on to our web site at

**[www.fmtool.com.au](http://www.fmtool.com.au)**

Select **TOOLING**; then under Product Group **THICK TURRET**, select **"EA", Parting & 'HD' Tooling (FM)** , choose your HD requirements listed under section **AA0.12**

**Pricing and description for all shapes, rounds and accessories for Thick Turret Tooling is available at this site**

## 'B' STATION HEAVY DUTY NIBBLING TOOLS ( up to 1 ¼" or 31.75mm dia )

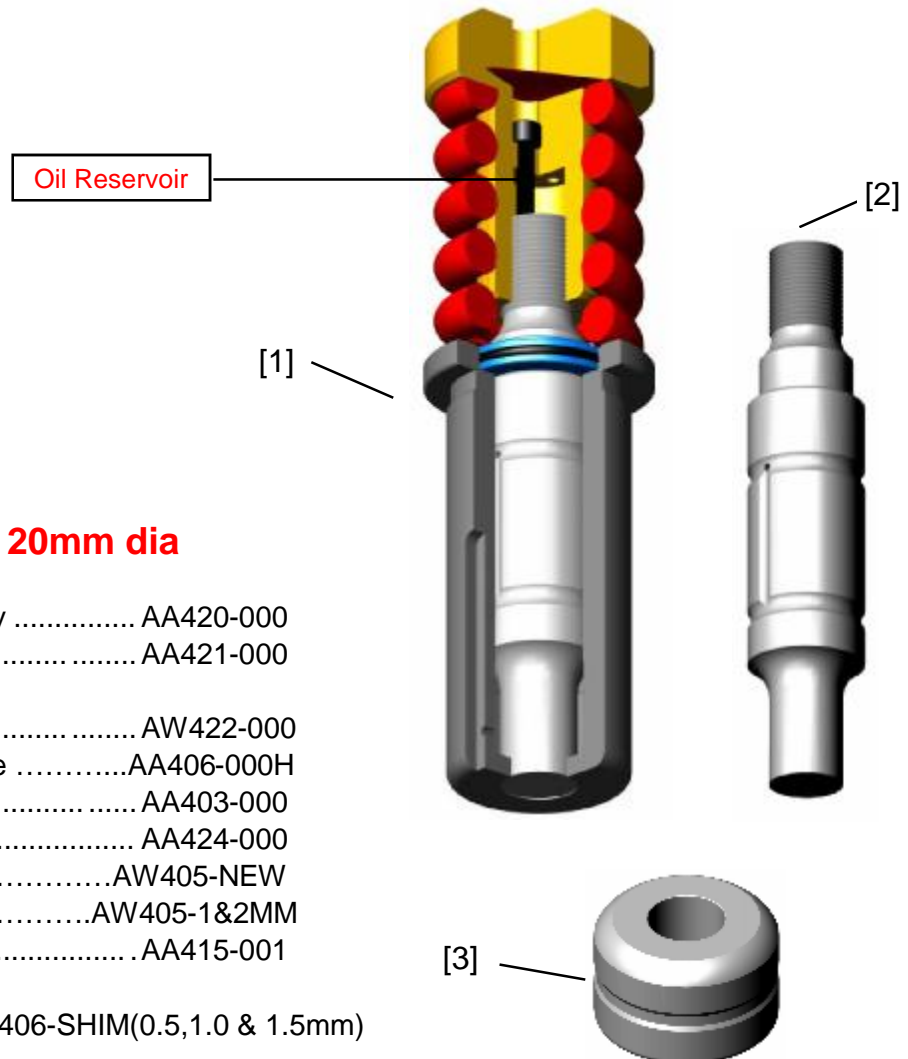

### Stock Size 20mm dia

- [1] Complete Punch Assembly ..... AA420-000
- [2] Punch Only..... AA421-000
- Hardened Precision
- Ground Guide ..... AW422-000
- [3] Solid Precision Ground Die .....AA406-000H
- Stripping Spring..... AA403-000
- Punch Head (complete)..... AA424-000
- 0 to 3mm Punch Shim Collar .....AW405-NEW
- 1 to 2mm Punch Shim Collar .....AW405-1&2MM
- O'Rings for Collars..... AA415-001
- Die Shims ea..... AA406-SHIM(0.5,1.0 & 1.5mm)

For **PRICING** and extended description of the tooling on this page log on to our web site at  
**[www.fmtool.com.au](http://www.fmtool.com.au)**

Select **TOOLING**; then under Product Group **THICK TURRET**, select **"EA", Parting & 'HD' Tooling (FM)**, choose your HD requirements listed under section **AA0.12**  
Pricing and description for all shapes, rounds and accessories for Thick Turret Tooling is available at this site

# FM TOOL

Features Through The Tool Lubrication

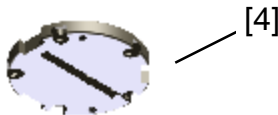
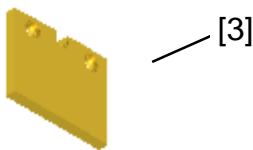
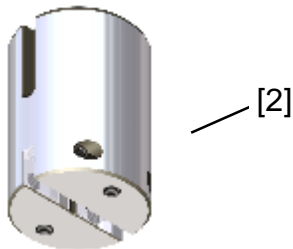
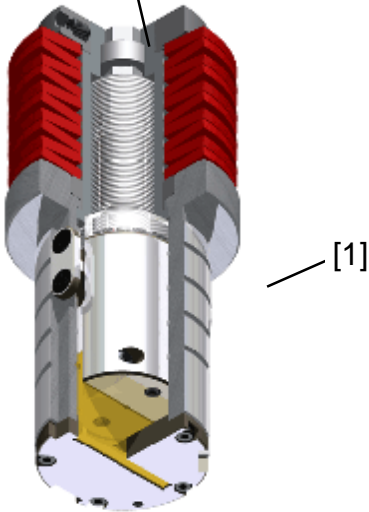

## HIGH PERFORMANCE, ECONOMICAL HEAVY DUTY PUNCHING, PARTING & NOTCHING TOOLS

### 'C' Station

### PUSH BUTTON ADJUSTABLE

**\*Features Through-The-Tool Lubrication\***

NO SHIMS REQUIRED Up to 10mm Adjustment

**[1] Guide Assembly .....AA560-SLIT**  
(does not include punch & stripper plate)

#### GUIDE COMPONENTS

Guide Body .....	AA560-001S
Adjustable Punch Driver Spigot.....	AA560-002
Spring Housing Spigot.....	AA560-003
Spring Retaining Ring .....	AA560-004
Spring Retaining Head .....	AA560-005
Disc Spring (ea) .....	AA554-001
Guide Body Punch Locating Key.....	AA950-001
T' Handle.....	AA962-000

#### TOOLING

Punch, Die & Stripper Set (as ordered) ..	AA500HD-XXX
Punch (as ordered) .....	AA501-XXX
Stripper (as ordered) .....	AA565-XXX
Die (as ordered) .....	AA503-XXX

#### PARTING TOOLS

(refer to page 8)

#### NOTCHING

(Stock Size 25 x 25mm)

[5] Punch (Shear Proof).....	AA501-200S
Stripper .....	AA565-200



For **PRICING** and extended description of the tooling on this page log on to our web site at

**[www.fmtool.com.au](http://www.fmtool.com.au)**

Select **TOOLING**; then under Product Group **THICK TURRET**, select **"EA", Parting & 'HD' Tooling (FM)**, choose your C' St Parting & Notching Tool requirements

listed under section **AA0.12**

Pricing and description for all shapes, rounds and accessories for Thick Turret Tooling is available at this site



# FM TOOL

## HIGH PERFORMANCE, ECONOMICAL HEAVY DUTY PUNCHING, PARTING & NOTCHING TOOLS

Features Through The  
Tool Lubrication

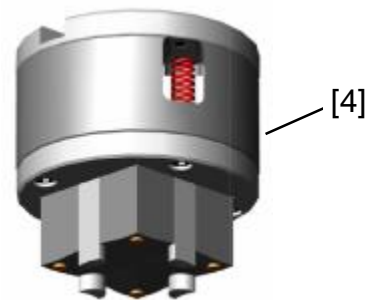
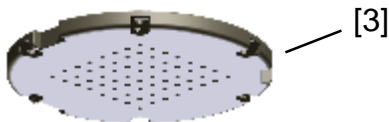
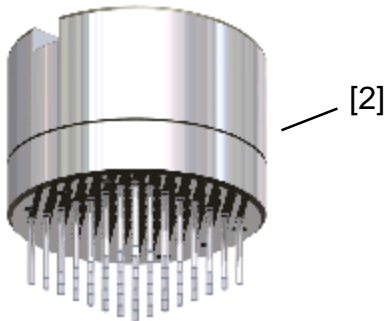
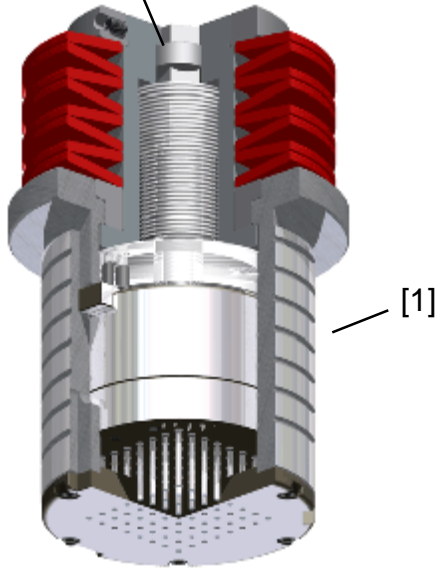

### 'D' Station

### PUSH BUTTON ADJUSTABLE

**\*Features Through-The-Tool Lubrication\***

NO SHIMS REQUIRED Up to 10mm Adjustment

[1] Guide Assembly ..... AA860HD-000  
(does not include punch & stripper plate)

### GUIDE COMPONENTS

Guide Body .....	AA860HD-001
Adjustable Punch Driver Spigot.....	AA860-002
Spring Housing Spigot.....	AA860-003
Spring Retaining Ring .....	AA860-004
Spring Retaining Head .....	AA860-005
Disc Spring (ea) .....	AA1052-000
T' Handle.....	AA962-000

### TOOLING

Punch, Die & Stripper Set (as ordered) ..	AA700HD-XXX
[2] Punch (as ordered).....	AA701-XXX
[3] Stripper Plate (as ordered) .....	AA752-XXX
Die (as ordered) .....	AA703-XXX

### PARTING TOOLS

(refer to page 8)

### NOTCHING

(Stock Size 50 x 50mm)

[4] Punch (Shear Proof).....	AA701-200S
Stripper .....	AA752-200

For **PRICING** and extended description of the tooling on this page log on to our web site at  
**[www.fmtool.com.au](http://www.fmtool.com.au)**

Select **TOOLING**; then under Product Group **THICK TURRET**, select **"EA", Parting & 'HD' Tooling (FM)**, then **"D" 'HD' Punching, Parting & Notching**  
choose your Tool requirements listed under section **A0.12D1**

Pricing and description for all shapes, rounds and accessories for Thick Turret Tooling  
is available at this site

# FM TOOL

Features Through The Tool Lubrication

## HIGH PERFORMANCE, ECONOMICAL HEAVY DUTY PUNCHING, PARTING & NOTCHING TOOLS

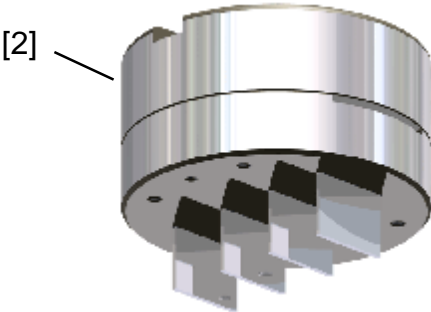
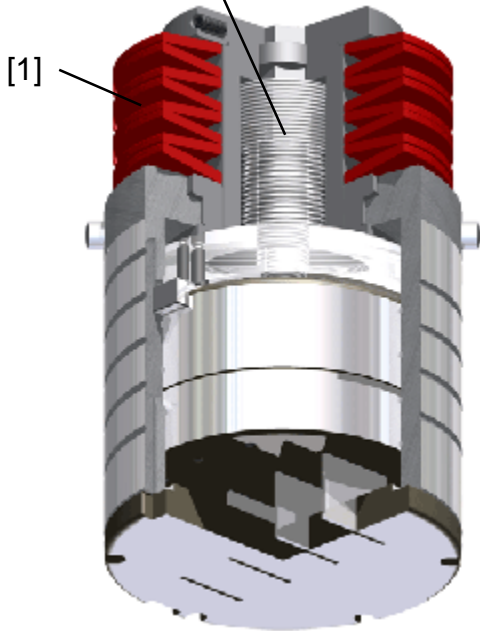

### 'E' Station

### PUSH BUTTON ADJUSTABLE

\*Features Through-The-Tool Lubrication\*

NO SHIMS REQUIRED Up to 10mm Adjustment

[1] Guide Assembly ..... AA1060HD-000  
(does not include punch & stripper plate)

### GUIDE COMPONENTS

Guide Body ..... AA1060HD-001  
Adjustable Punch Driver Spigot ..... AA1060-002  
Spring Housing Spigot..... AA860-003  
Spring Retaining Ring ..... AA860-004  
Spring Retaining Head ..... AA860-005  
Disc Spring (ea) ..... AA1052-000  
T' Handle..... AA962-000

### TOOLING

Punch, Die & Stripper Set (as ordered) .. AA900HD-XXX  
[2] Punch (as ordered)..... AA901-XXX  
[3] Stripper (as ordered) ..... AA952-XXX  
Die (as ordered) ..... AA903-XXX

### PARTING TOOLS

(refer to page 8)

### NOTCHING

(Stock Size 70 x 70mm)

[5] Punch (Shear Proof)..... AA901-200S  
Stripper ..... AA952-200

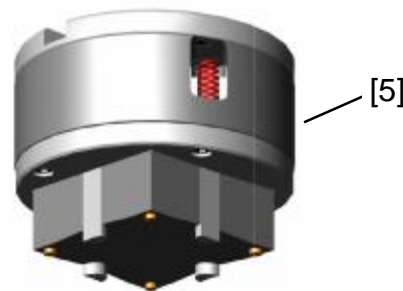

For **PRICING** and extended description of the tooling on this page log on to our web site at  
**[www.fmtool.com.au](http://www.fmtool.com.au)**

Select **TOOLING**; then under Product Group **THICK TURRET**, select **"EA"**, Parting & **'HD' Tooling (FM)**, then **"E"** **'HD' Punching, Parting & Notching**  
choose your Tool requirements listed under section **AA0.12E1**

Pricing and description for all shapes, rounds and accessories for Thick Turret Tooling  
is available at this site

**‘C’, ‘D’ & ‘E’ STATION  
PARTING TOOL SYSTEMS**

**Econo Style Parting Tools**

For AA560-SLIT, AA860HD-000 & AA1060HD-000  
Assemblies

5 x 50, 5 x 80, 5 x 110mm Held in Stock

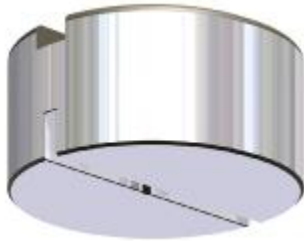

**HOLDERS**

- “C” Station..... AA561-000
- “D” Station..... AA740-000
- “E” Station..... AA940-000

**INSERTS**

- “C” Station Punch Insert (5 x 50mm Stock Size)..... AA562-300
- “C” Station Punch Insert (Micro Joint) ..... AA562-605
- “D” Station Punch Insert (5 x 80mm Stock Size)..... AA741-300
- “D” Station Punch Insert (Micro Joint) ..... AA741-605
- “E” Station Punch Insert (5 x 110mm Stock Size) ..... AA941-300
- “E” Station Punch Insert (Micro Joint)..... AA941-605

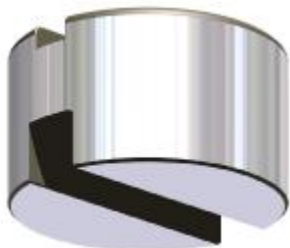
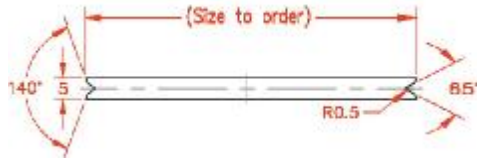

**Heavy Duty Holders & Inserts**

For 5 x 80, 10 x 80, 5 x 110 & 10 x 110mm stock sizes

**HOLDERS**

- “D” Station (16mm locating pin) ..... AA730-000
- “E” Station (16mm locating pin) ..... AA930-000

**INSERTS**

- “D” Station (16mm locating key)..... AA731-300
- “E” Station (16mm locating key)..... AA931-300

**WILSON DESIGN INSERTS**

(only suitable for Wilson Design Holders)

- “D” Station (1/4” locating key)..... AW731-300
- “E” Station (1/4” locating key)..... AW931-300

For **PRICING** and extended description of the tooling on this page log on to our web site at

**[www.fmtool.com.au](http://www.fmtool.com.au)**

Select **TOOLING**; then under Product Group **THICK TURRET**, select **“EA”, Parting & ‘HD’ Tooling (FM)**, then **“D” or “E” ‘HD’ Punching, Parting & Notching** choose your Tool requirements listed under section **AA0.12D1** for D St. & **AA0.12E1** for E St. Pricing and description for all shapes, rounds and accessories for Thick Turret Tooling is available at this site

# FM TOOL

## HIGH PERFORMANCE, ECONOMICAL, CLOSE-TO-CLAMP, PARTING TOOLS

Features Through The  
Tool Lubrication



### 'D' Station

### PUSH BUTTON ADJUSTABLE

\*Features Through-The-Tool Lubrication\*  
NO SHIMS REQUIRED Up to 10mm Adjustment

### PARTING

(Stock Size 5 x 80mm Rectangle)

( Other Sizes & Shapes may incur a surcharge )

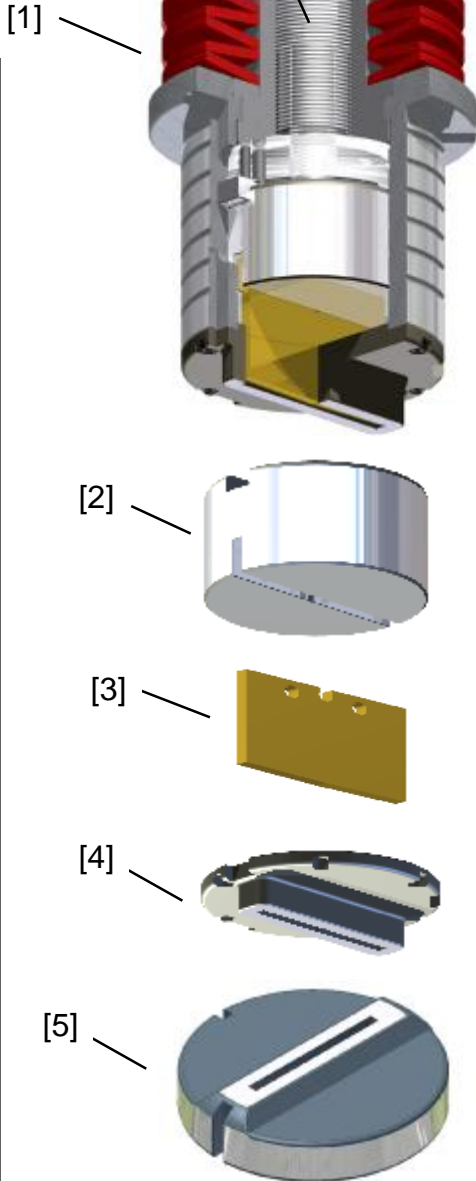

[1] Guide Assembly ..... AA860-SLIT  
(does not include punch & stripper plate)

### GUIDE COMPONENTS

Guide Body.....	AA860-001S
Adjustable Punch Driver Spigot .....	AA860-002
Spring Housing Spigot .....	AA860-003
Spring Retaining Ring.....	AA860-004
Spring Retaining Head.....	AA860-005
Disc Spring (ea).....	AA1052-000
Punch Locating Key.....	AA950-000
Punch Holding Stud.....	AA952-001
Octagonal Indexing Button.....	AA952-002
T' Handle .....	AA962-000

### TOOLING

[2] Holder for Insert.....	AA861-000
[3] Punch Insert (Rectangle) .....	AA862-300
[4] Stripper (Rectangle).....	AA865-300
Punch Insert (Micro Joint) .....	AA862-605
Stripper (Micro Joint) .....	AA865-605
[5] Die (Rectangle).....	AA703CC-300
Die (Micro Joint) .....	AA703CC-605

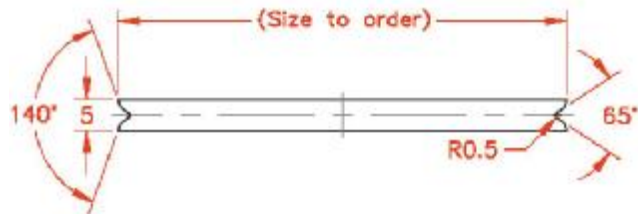

For **PRICING** and extended description of the tooling on this page log on to our web site at

[www.fmtool.com.au](http://www.fmtool.com.au)

Select **TOOLING**; then under Product Group **THICK TURRET**, select **"EA", Parting & 'HD' Tooling (FM)**, then **"D" 'HD' Punching, Parting & Notching** choose your **D' St Close-to-Clamp Tool requirements listed under section AA0.12D2**  
Pricing and description for all shapes, rounds and accessories for Thick Turret Tooling is available at this site

# FM TOOL

## HIGH PERFORMANCE, ECONOMICAL, CLOSE-TO-CLAMP, PARTING TOOLS

Features Through The  
Tool Lubrication

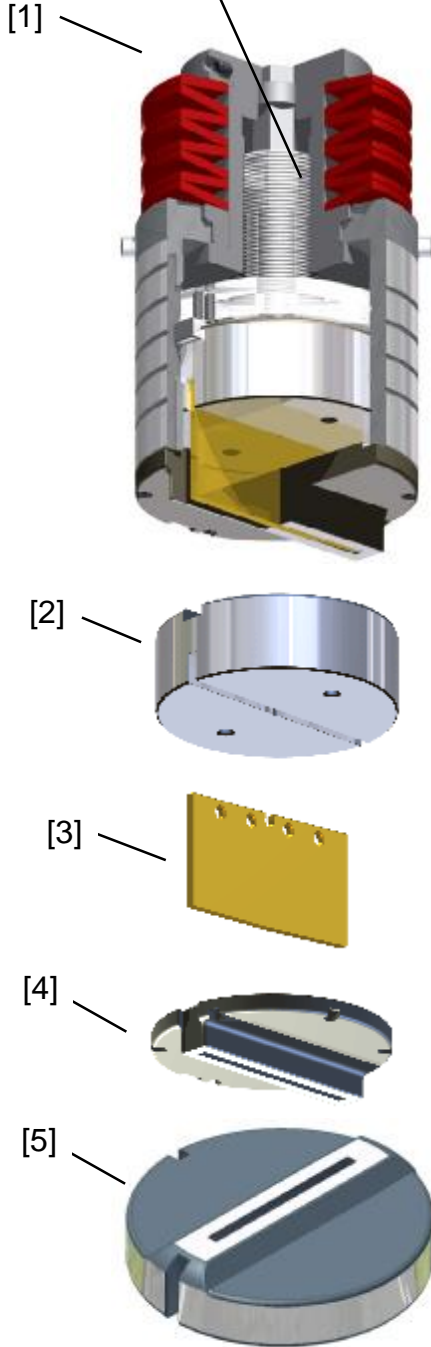

### 'E' Station

#### PUSH BUTTON ADJUSTABLE

**\*Features Through-The-Tool Lubrication\***  
NO SHIMS REQUIRED Up to 10mm Adjustment

#### PARTING

**(Stock Size 5 x 110mm Rectangle)**

( Other Sizes & Shapes may incur a surcharge )

**[1] Guide Assembly ..... AA1060-SLIT**  
(does not include punch & stripper plate)

#### GUIDE COMPONENTS

Guide Body.....	AA1060-001S
Adjustable Punch Driver Spigot .....	AA1060-002
Spring Housing Spigot.....	AA860-003
Spring Retaining Ring.....	AA860-004
Spring Retaining Head.....	AA860-005
Disc Spring (ea).....	AA1052-000
Punch Locating Key.....	AA950-000
Punch Holding Stud.....	AA952-001
Octagonal Indexing Button.....	AA952-002
T' Handle .....	AA962-000

#### TOOLING

[2] Holder for Insert.....	AA1061-000
[3] Punch Insert (Rectangle) .....	AA1062-300
[4] Stripper (Rectangle).....	AA1065-300
Punch Insert (Micro Joint).....	AA1062-605
Stripper (Micro Joint) .....	AA1065-605
[5] Die (Rectangle).....	AA903CC-300
Die (Micro Joint) .....	AA903CC-605

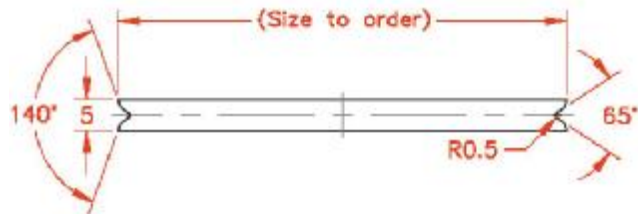

For **PRICING** and extended description of the tooling on this page log on to our web site at

**[www.fmtool.com.au](http://www.fmtool.com.au)**

Select **TOOLING**; then under Product Group **THICK TURRET**, select **"EA", Parting & 'HD' Tooling (FM)**, then **"E" 'HD' Punching, Parting & Notching**, choose your **E' St Close-to-Clamp Tool requirements listed under section AA0.12E2**  
**Pricing and description for all shapes, rounds and accessories for Thick Turret Tooling is available at this site**

# FM TOOL

## HIGH PRECISION LINE-UP TOOLS (WILL ALIGN CONCENTRICITY & KEYING)



*AVAILABLE FOR SALE & HIRE*

'A' Station.....	AA100-888
'B' Station.....	AA300-888
'C' Station.....	AA500-888
'D' Station.....	AA700-888
'E' Station.....	AA900-888

## ADAPTOR SLEEVES



A to B stat Guide.....	AA175-000
A to B stat Die.....	AA176-000
B to D stat Guide.....	AA775-000
B to D stat Die.....	AA776-000

*other station adaptors available on request*

For **PRICING** and extended description of the tooling on this page log on to our web site at  
**[www.fmtool.com.au](http://www.fmtool.com.au)**

Select **TOOLING**; then under Product Group **THICK TURRET**, select **"EA", Parting & 'HD' Tooling (FM)**, choose your Accessories requirements listed under section **AA0.14**  
Pricing and description for all shapes, rounds and accessories for Thick Turret Tooling  
is available at this site

# AMADA

## Style

## Tooling

*Manufactured by*

**F.M. TOOL & GAUGE PTY. LTD.**

A.B.N. 91 008 262 520

CUDLEE CREEK, SOUTH AUSTRALIA, 5232

PH. (08) 8389 2272 FAX. (08) 8389 2309 or (08) 8389 2478

Free Call 1800 882 993 E-mail - [sales@fmtool.com.au](mailto:sales@fmtool.com.au)

[www.fmtool.com.au](http://www.fmtool.com.au)



# AMADA STYLE

**1/2" OR 'A' STATION**  
(up to 1/2" or 12.7mm dia)

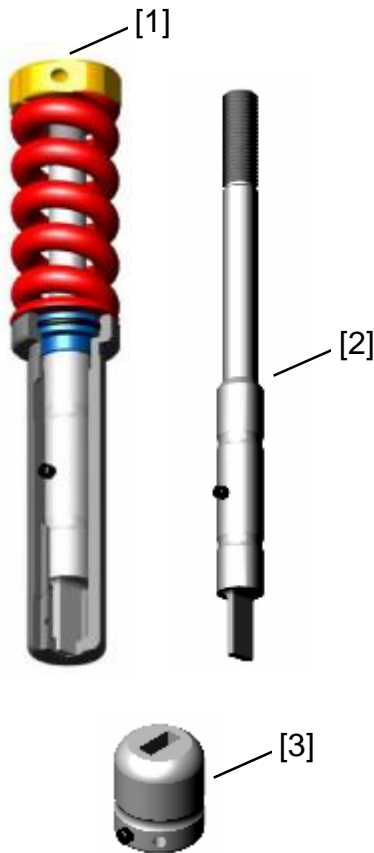

## Shapes

[1] Punch & Guide Assembly.....	AA100-XXX
[2] Punch Only.....	AA101-XXX
Guide Only.....	AA112-XXX
[3] Die.....	AA106-XXX

## Rounds

Punch & Guide Assembly.....	AA200-000
Punch Only.....	AA201-000
Guide Only.....	AA212-000
Die.....	AA206-000

## Assembly Parts

Super Locking Head.....	AA214-000
Stripping Spring.....	AA203-000
0 to 3mm Punch Shim Collar.....	AA215-NEW
1 to 2mm Punch Shim Collar.....	AA215-1&2MM
O'Ring for Collars.....	AA215-001

Die Shims ea. .... AA206-SHIM(0.5,1.0 & 1.5mm)

## Air Blow Punches & Guides

[4] Shaped Punch.....	AA171-XXX
Round Punch.....	AA271-000
[5] Shaped Guides.....	AA172-XXX
Round Guides.....	AA272-000

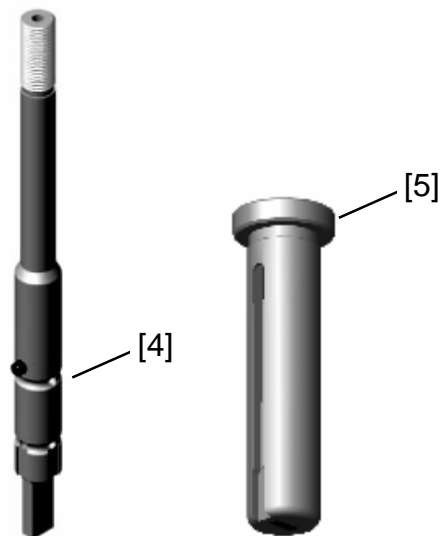

For **PRICING** and extended description of the tooling on this page log on to our web site at  
**[www.fmtool.com.au](http://www.fmtool.com.au)**

Select **TOOLING**; then under Product Group **THICK TURRET**, select **AMADA STYLE**, choose your A Station requirements listed under section **AA0.5**

Pricing and description for all shapes, rounds and accessories for Thick Turret Tooling is available at this site



# AMADA STYLE

**1 1/4" OR 'B' STATION**  
(up to 1 1/4" or 31.75mm dia)

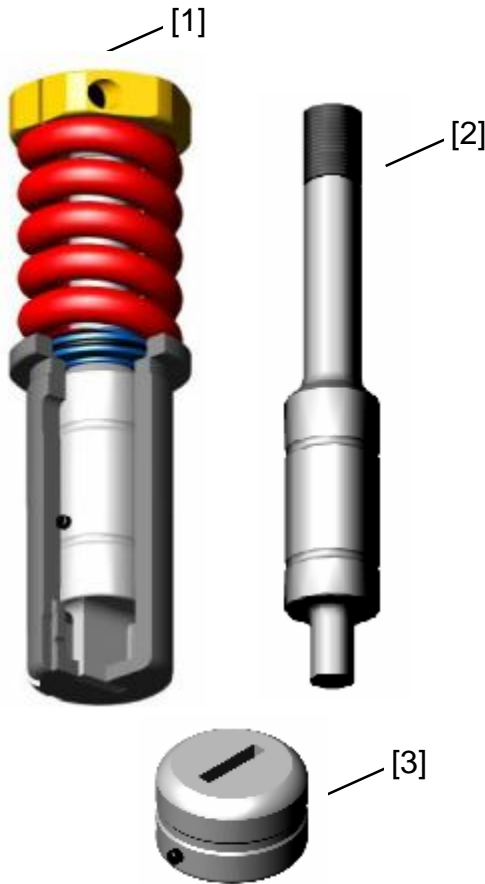

## Shapes

[1] Punch & Guide Assembly .....	AA300-XXX
Punch Only .....	AA301-XXX
Guide Only .....	AW302-XXX
[3] Die .....	AA306-XXX

## Rounds

Punch & Guide Assembly .....	AA400-000
[2] Punch Only .....	AA401-000
Guide Only .....	AW402-000
Die .....	AA406-000

## Assembly Parts

Super Locking Head.....	AA414-000
Stripping Spring.....	AA403-000
0 to 3mm Punch Shim Collar .....	AA415-NEW
1 to 2mm Punch Shim Collar .....	AA415-1&2MM
O'Ring for Collars .....	AA415-001
Die Shims ea. ....	AA406-SHIM(0.5,1.0 & 1.5mm)

## Air Blow Punches & Guides

[4] Shaped Punch.....	AA371-XXX
Round Punch.....	AA471-000
[5] Shaped Guide.....	AW372-XXX
Round Guide .....	AW472-000

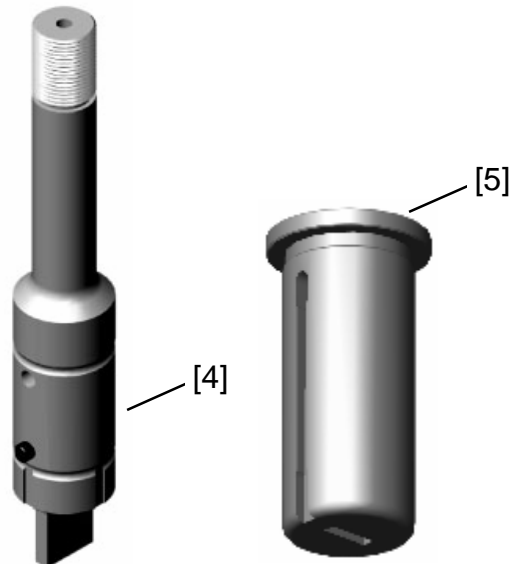

For **PRICING** and extended description of the tooling on this page log on to our web site at [www.fntool.com.au](http://www.fntool.com.au)

Select **TOOLING**; then under Product Group **THICK TURRET**, select **AMADA STYLE**, choose your B Station requirements listed under section **AA1.25**

Pricing and description for all shapes, rounds and accessories for Thick Turret Tooling is available at this site

# AMADA STYLE

## 2" OR 'C' STATION (up to 2" or 50.8mm dia)

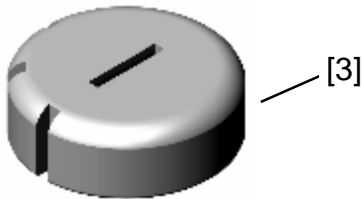
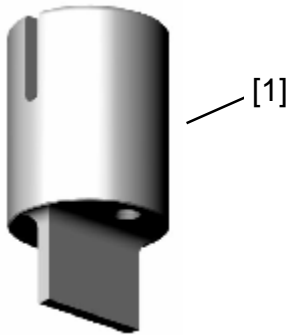

### Shapes

Punch, Die & Stripper Set .....	AA500-XXX
[1] Punch Only .....	AA501-XXX
[2] Stripper .....	AA502-XXX
[3] Die .....	AA503-XXX

### Rounds

Punch, Die & Stripper Set .....	AA600-000
Punch Only .....	AA601-000
Stripper .....	AA602-000
Die .....	AA603-000
Die Shims ea. ....	AA503-SHIM(0.5,1.0 & 1.5mm)

### Air Blow Punches & Strippers

[4] Punch Shaped .....	AA571-XXX
Punch Round.....	AA671-000
[5] Stripper Shaped.....	AA572-XXX
Stripper Round .....	AA672-000

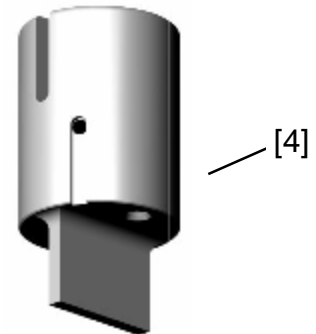

For **PRICING** and extended description of the tooling on this page log on to our web site at [www.fntool.com.au](http://www.fntool.com.au)

Select **TOOLING**; then under Product Group **THICK TURRET**, select **AMADA STYLE**, choose your C Station requirements listed under section **AA2.0**

Pricing and description for all shapes, rounds and accessories for Thick Turret Tooling is available at this site

# AMADA STYLE

## 'C' STATION GUIDE ASSEMBLIES

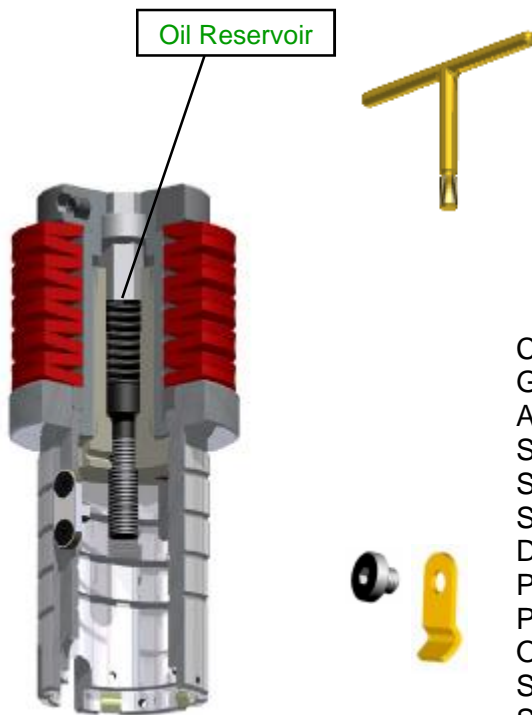

### PUSH BUTTON ADJUSTABLE

**\*Features Through-The-Tool Lubrication\***

(NO SHIMS REQUIRED)

Up to 10mm adjustment

Complete Guide Assembly .....	AA560-000
Guide Body.....	AA560-001
Adjustable Punch Driver Spigot .....	AA560-002
Spring Housing Spigot.....	AA560-003
Spring Retaining Ring.....	AA560-004
Spring Retaining Head.....	AA560-005
Disc Spring (ea)(45mm I.D.) .....	AA554-001
Punch Locating Key.....	AA950-001
Punch Holding Stud.....	AA952-001
Octagonal Indexing Button.....	AA952-002
Stripper Holding Clips (ea).....	AA960-000
Stripper Holding Clip Screws (ea) .....	AA961-000
T' Handle .....	AA962-000

### STANDARD ASSEMBLY

**(Original Amada Style)**

(HEAVY PUNCHING)

(SHIMS REQUIRED)



Complete Guide Assembly .....	AA550-000
Head.....	AA551-000
Spigot.....	AA552-000
Guide Body.....	AA553-000
Disc Spring (ea)(40mm I.D.) .....	AA554-000
Punch Locating Key.....	AA950-001
Punch Holding Stud.....	AA952-000
Stripper Holding Clips (ea).....	AA960-000
Stripper Holding Clip Screws (ea) .....	AA961-000
T' Handle .....	AA962-000
Punch Adjusting Shims.....	AA501-SHIM (1, 2, & 3mm)

For **PRICING** and extended description of the tooling on this page log on to our web site at

**[www.fmtool.com.au](http://www.fmtool.com.au)**

Select **TOOLING**; then under Product Group **THICK TURRET**, select **AMADA STYLE**, choose your C Station Assembly requirements listed under section **AA2.0**

Pricing and description for all shapes, rounds and accessories for Thick Turret Tooling is available at this site

# AMADA STYLE

**3 1/2" OR 'D' STATION**  
(up to 3 1/2" or 88.9mm dia)

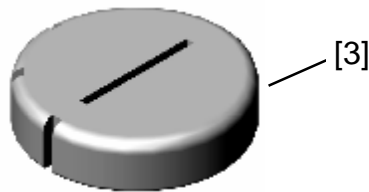
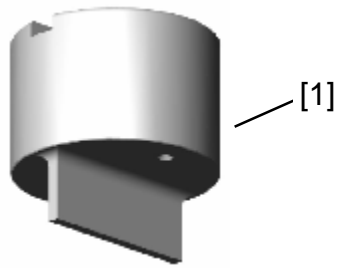

## Shapes

Punch, Die & Stripper Set .....	AA700-XXX
[1] Punch Only .....	AA701-XXX
[2] Stripper .....	AA702-XXX
[3] Die .....	AA703-XXX

## Rounds

Punch, Die & Stripper Set .....	AA800-000
Punch Only .....	AA801-000
Stripper .....	AA802-000
Die .....	AA803-000

Die Shims ea..... AA703-SHIM(0.5,1.0 & 1.5mm)

---

## Air Blow Punches & Strippers

[4] Punch Shaped .....	AA771-XXX
Punch Round.....	AA871-000
[5] Stripper Shaped.....	AA772-XXX
Stripper Round .....	AA872-000

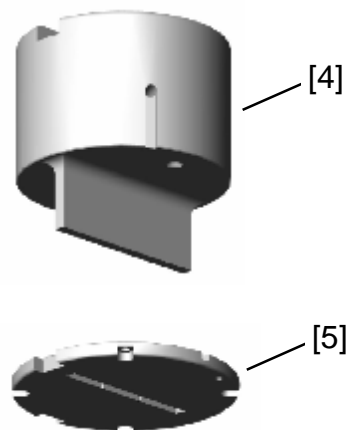

For **PRICING** and extended description of the tooling on this page log on to our web site at  
**[www.fntool.com.au](http://www.fntool.com.au)**

Select **TOOLING**; then under Product Group **THICK TURRET**, select **AMADA STYLE**, choose your D Station requirements listed under section **AA3.5**

Pricing and description for all shapes, rounds and accessories for Thick Turret Tooling is available at this site

# AMADA STYLE

## 'D' STATION GUIDE ASSEMBLIES

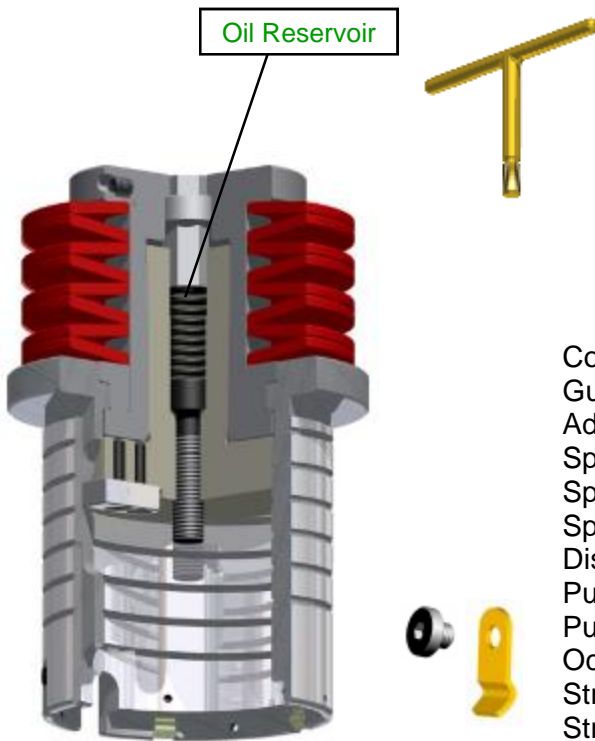

### PUSH BUTTON ADJUSTABLE

**\*Features Through-The-Tool Lubrication\***

(NO SHIMS REQUIRED)

Up to 10mm Adjustment

Complete Guide Assembly .....	AA860-000
Guide Body.....	AA860-001
Adjustable Punch Driver Spigot .....	AA860-002
Spring Housing Spigot.....	AA860-003
Spring Retaining Ring.....	AA860-004
Spring Retaining Head.....	AA860-005
Disc Spring (ea) .....	AA1052-000
Punch Locating Key.....	AA950-000
Punch Holding Stud.....	AA952-001
Octagonal Indexing Button.....	AA952-002
Stripper Holding Clips (ea).....	AA960-000
Stripper Holding Clip Screws (ea).....	AA961-000
T' Handle .....	AA962-000

### STANDARD ASSEMBLY (Original Amada Style)

(HEAVY PUNCHING)

(SHIMS REQUIRED)



Complete Guide Assembly .....	AA850-000
Head.....	AA851-000
Spigot.....	AA853-000
Guide Body.....	AA854-000
Disc Spring (ea) .....	AA1052-000
Punch Locating Key.....	AA950-000
Punch Holding Stud.....	AA951-000
Stripper Holding Clips (ea).....	AA960-000
Stripper Holding Clip Screws (ea).....	AA961-000
T' Handle .....	AA962-000

Punch Adjusting Shims.....	AA701-SHIM (1, 2, & 3mm)
----------------------------	-----------------------------

For **PRICING** and extended description of the tooling on this page log on to our web site at  
**[www.fntool.com.au](http://www.fntool.com.au)**

Select **TOOLING**; then under Product Group **THICK TURRET**, select **AMADA STYLE**, choose your D Station Assemblies requirements listed under section **AA3.5**

Pricing and description for all shapes, rounds and accessories for Thick Turret Tooling is available at this site

# AMADA STYLE

**4 1/2" OR 'E' STATION**  
(up to 4 1/2" or 114.3mm dia)

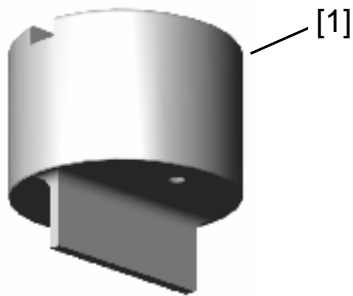

## Shapes

Punch, Die & Stripper Set.....	AA900-XXX
[1] Punch Only .....	AA901-XXX
[2] Stripper.....	AA902-XXX
[3] Die.....	AA903-XXX

## Rounds

Punch, Die & Stripper Set.....	AA1000-000
Punch Only.....	AA1001-000
Stripper.....	AA1002-000
Die.....	AA1003-000

Die Shims ea. ....AA903-SHIM(0.5,1.0 & 1.5mm)

## Air Blow Punches & Strippers

[4] Punch Shaped .....	AA971-XXX
Punch Round .....	AA1071-000
[5] Stripper Shaped .....	AA972-XXX
Stripper Round.....	AA1072-000

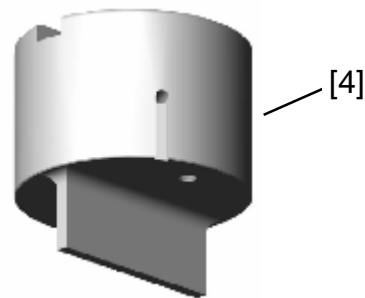

For **PRICING** and extended description of the tooling on this page log on to our web site at  
**[www.fntool.com.au](http://www.fntool.com.au)**

Select **TOOLING**; then under Product Group **THICK TURRET**, select **AMADA STYLE**, choose your E Station requirements listed under section **AA4.5**

Pricing and description for all shapes, rounds and accessories for Thick Turret Tooling is available at this site

# AMADA STYLE

## 'E' STATION GUIDE ASSEMBLIES

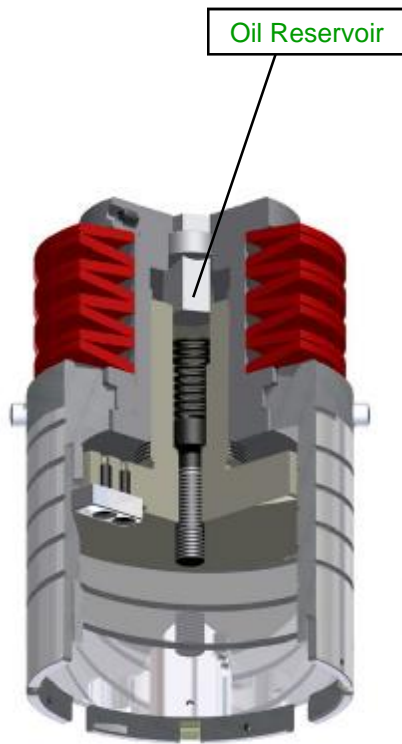

### PUSH BUTTON ADJUSTABLE

**\*Features Through-The-Tool Lubrication\***

(NO SHIMS REQUIRED)

Up to 10mm Adjustment



Complete Guide Assembly .....	AA1060-000
Guide Body .....	AA1060-001
Adjustable Punch Driver Spigot .....	AA1060-002
Spring Housing Spigot.....	AA860-003
Spring Retaining Ring.....	AA860-004
Spring Retaining Head.....	AA860-005
Disc Spring (ea) .....	AA1052-000
Punch Locating Key.....	AA950-000
Punch Holding Stud.....	AA952-001
Octagonal Indexing Button.....	AA952-002
Stripper Holding Clips (ea).....	AA960-000
Stripper Holding Clip Screws (ea).....	AA961-000
T' Handle .....	AA962-000

### STANDARD ASSEMBLY

**(Original Amada Style)**

(HEAVY PUNCHING)

(SHIMS REQUIRED)



Complete Guide Assembly .....	AA1050-000
Head .....	AA1051-000
Spigot .....	AA1053-000
Guide Body .....	AA1054-000
Disc Spring (ea) .....	AA1052-000
Punch Locating Key.....	AA950-000
Punch Holding Stud.....	AA951-000
Stripper Holding Clips (ea).....	AA960-000
Stripper Holding Clip Screws (ea).....	AA961-000
T' Handle .....	AA962-000
Punch Adjusting Shims.....	AA901-SHIM (1, 2, & 3mm)

For **PRICING** and extended description of the tooling on this page log on to our web site at

**[www.fntool.com.au](http://www.fntool.com.au)**

Select **TOOLING**; then under Product Group **THICK TURRET**, select **AMADA STYLE**, choose your E Station Assemblies requirements listed under section **AA4.5**

Pricing and description for all shapes, rounds and accessories for Thick Turret Tooling is available at this site

# WILSON

## Style

## Tooling

*Manufactured by*

**F.M. TOOL & GAUGE PTY. LTD.**

A.B.N. 91 008 262 520

CUDLEE CREEK, SOUTH AUSTRALIA, 5232

PH. (08) 8389 2272 FAX. (08) 8389 2309 or (08) 8389 2478

Free Call 1800 882 993 E-mail - [sales@fmtool.com.au](mailto:sales@fmtool.com.au)

[www.fmtool.com.au](http://www.fmtool.com.au)





# WILSON STYLE

## '20' STATION MULTI TOOLS

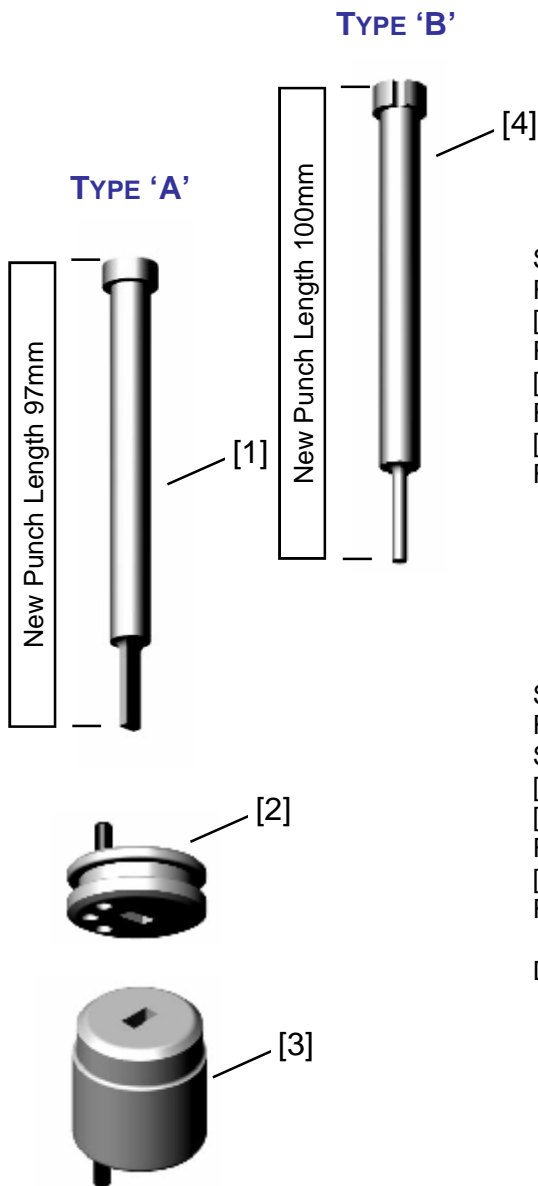

Up to 8mm Dia  
Type 'A'

Shaped Punch, Die & Stripper Set.....	AWT20-0-XXX
Round Punch, Die & Stripper Set .....	AWT20-0-000
[1] Shaped Punch Only .....	AWT20-1-XXX
Round Punch Only .....	AWT20-1-000
[3] Shaped Die .....	AMT20-2-XXX
Round Die .....	AMT20-2-000
[2] Shaped Stripper .....	AMT20-3-XXX
Round Stripper .....	AMT20-3-000

### Type 'B'

Shaped Punch, Die & Stripper Set.....	AWT20A-0-XXX
Round Punch, Die & Stripper Set .....	AWT20A-0-000
Shaped Punch Only .....	AWT20A-1-XXX
[4] Round Punch Only .....	AWT20A-1-000
[3] Shaped Die .....	AMT20-2-XXX
Round Die .....	AMT20-2-000
[2] Shaped Stripper .....	AMT20-3-XXX
Round Stripper .....	AMT20-3-000
Die Shims ea.....	AMT20-2-SHIM(0.5,1.0 & 1.5mm)

For **PRICING** and extended description of the tooling on this page log on to our web site at  
[www.fmtool.com.au](http://www.fmtool.com.au)

Select **TOOLING**; then under Product Group **THICK TURRET**, select **WILSON  
STYLE**, choose your Multi Tool requirements listed under section **A0.3W**  
Pricing and description for all shapes, rounds and accessories for Thick Turret Tooling  
is available at this site

# WILSON Series 90 STYLE

**1/2" OR 'A' STATION**  
(up to 1/2" or 12.7mm dia)

Features Through The  
Tool Lubrication

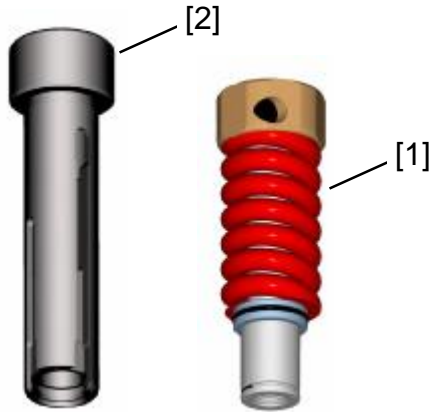

## OPEN GUIDE & STRIPPING UNIT

HARDENED AND PRECISION GROUND  
Suitable for all 1/2" Stations

- [1] Stripping Unit.....AW180-000
- [2] Open Guide .....AW182-001  
(keyed at 0, 135, 225 deg.)
- [2] Open Guide .....AW182-002  
(keyed at 0, 90, 180, 270 deg.)

### Accessories

- Stripping Spring .....AW203-000
- Punch Head .....AW204-000
- Collar.....AW205-NEW
- Spigot.....AW292-000
- Wire Circlip.....AW293-000

## ADJUSTABLE PUNCH, DIE & GUIDE SETS

### Shapes

- [3] Punch, Die & Stripper Set .....AW190-XXX
- [4] Punch, Die & Guide Set.....AW196-XXX
- Punch.....AW191-XXX
- Guide .....AW102-XXX
- Stripper (to suit open guide) .....AA185-XXX
- Die.....AA106-XXX

### Rounds

- [3] Punch, Die & Stripper Set .....AW290-000
- [4] Punch, Die & Guide Set.....AW296-000
- Punch.....AW291-000
- Guide .....AW202-000
- Stripper (to suit open guide) .....AA185-000
- Die.....AA206-000

Die Shims ea. .... AA206-SHIM(0.5,1.0 & 1.5mm)

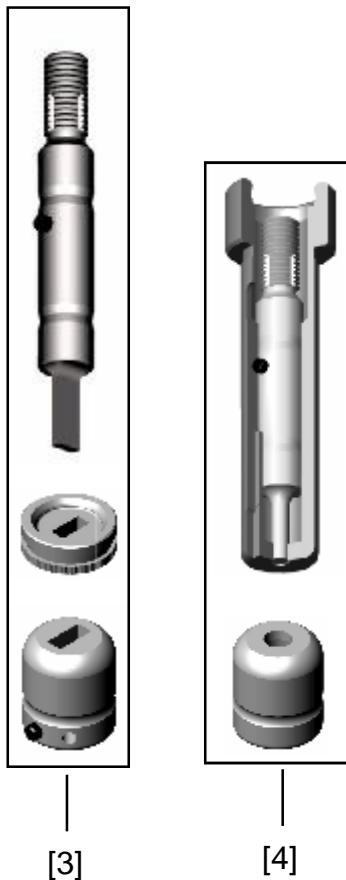

For **PRICING** and extended description of the tooling on this page log on to our web site at  
[www.fmtool.com.au](http://www.fmtool.com.au)

Select **TOOLING**; then under Product Group **THICK TURRET**, select **WILSON STYLE**, choose your A' St Series 90 requirements listed under section **A0.3W**  
Pricing and description for all shapes, rounds and accessories for Thick Turret Tooling is available at this site

# WILSON Series 90 STYLE

**1 1/4" OR 'B' STATION**  
(up to 1 1/4" or 31.75mm dia)

Features Through The  
Tool Lubrication

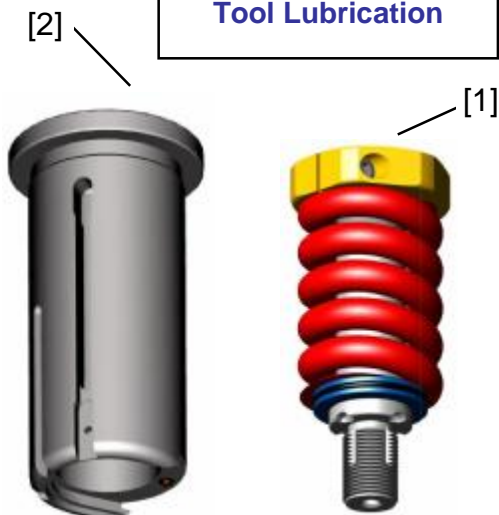

## OPEN GUIDE & STRIPPING UNIT

HARDENED AND PRECISION GROUND  
Suitable for all 1 1/4" Stations

- [1] Stripping Unit .....AA380-000
- [2] Open Guide.....AA382-001  
(keyed at 0, 45, 90, 135 deg.)
- [2] Open Guide.....AA382-002  
(keyed at 0, 90, 180, 270 deg.)

### Accessories

- Stripping Spring .....AA403-000
- Punch Head .....AW414-000
- Collar.....AW405-NEW
- Spigot.....AA407-000
- Wire Circlip.....AA393-000
- Wind-inCirclip.....AA393-001
- Plunger.....AA393-002

## ADJUSTABLE PUNCH, DIE & GUIDE SETS

### Shapes

- [3] Punch, Die & Stripper Set.....AA390-XXX
- [4] Punch, Die & Guide Set.....AA396-XXX
- Punch.....AA381-XXX
- Guide .....AW302-XXX
- Stripper (to suit open guide) .....AA385-XXX
- Die.....AA306-XXX

### Rounds

- [3] Punch, Die & Stripper Set.....AA490-000
- [4] Punch, Die & Guide Set.....AA496-000
- Spigot Punch.....AA481-000
- Guide .....AW402-000
- Stripper (to suit open guide) .....AA385-000
- Die.....AA406-000

Die Shims ea.....AA406-SHIM(0.5,1.0 & 1.5mm)

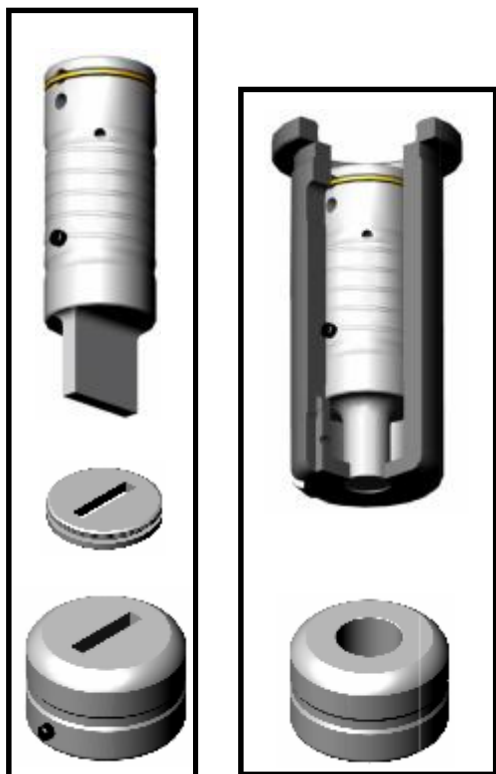

[3]

[4]

For **PRICING** and extended description of the tooling on this page log on to our web site at  
**[www.fmtool.com.au](http://www.fmtool.com.au)**

Select **TOOLING**; then under Product Group **THICK TURRET**, select **WILSON  
STYLE**, choose your B' St Series 90 requirements listed under section **A0.3W**

Pricing and description for all shapes, rounds and accessories for Thick Turret Tooling  
is available at this site

# WILSON Series 90 STYLE

# SPIGOT PUNCHES

## 'C' Station (up to 2" or 50.8mm dia)

### Shapes

Punch, Die & Stripper Set .....	AA580-XXX
[1] Punch Only .....	AA581-XXX
Stripper .....	AA502-XXX
[2] Wilson Style Stripper.....	AW502-XXX
[3] Die .....	AA503-XXX

### Rounds

Punch, Die & Stripper Set .....	AA680-000
Punch Only .....	AA681-000
Stripper .....	AA602-000
Wilson Style Stripper.....	AW602-000
Die .....	AA603-000
Die Shims ea.....	AA503-SHIM(0.5,1.0 & 1.5mm)

## 'D' Station

(up to 3 1/2" or 88.9mm dia)

### Shapes

Punch, Die & Stripper Set .....	AA780-XXX
[4] Punch Only .....	AA781-XXX
Stripper .....	AA702-XXX
[5] Wilson Style Stripper.....	AW702-XXX
[6] Die .....	AA703-XXX

### Rounds

Punch, Die & Stripper Set .....	AA880-000
Punch Only .....	AA881-000
Stripper .....	AA802-000
Wilson Style Stripper.....	AW802-000
Die .....	AA803-000
Die Shims ea.....	AA703-SHIM(0.5,1.0 & 1.5mm)

## 'E' Station

(up to 4 1/2" or 114.3mm dia)

### Shapes

Punch, Die & Stripper Set .....	AA980-XXX
[4] Punch Only .....	AA981-XXX
Stripper .....	AA902-XXX
[5] Wilson Style Stripper.....	AW902-XXX
[6] Die .....	AA903-XXX

### Rounds

Punch, Die & Stripper Set .....	AA1080-000
Punch Only .....	AA1081-000
Stripper .....	AA1002-000
Wilson Style Stripper.....	AW1002-000
Die .....	AA1003-000
Die Shims ea.....	AA903-SHIM(0.5,1.0 & 1.5mm)

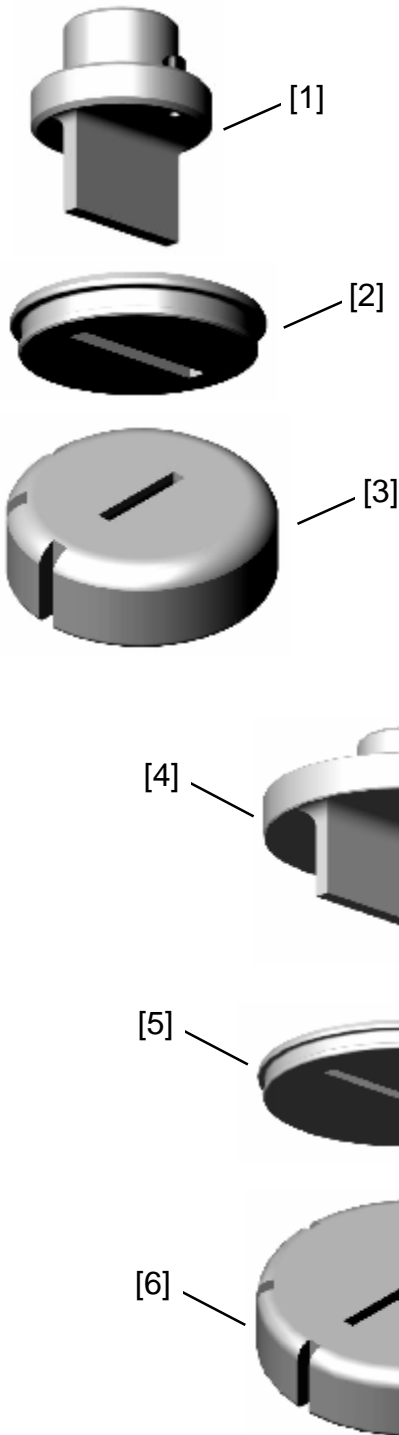

For **PRICING** and extended description of the tooling on this page log on to our web site at

[www.fmtool.com.au](http://www.fmtool.com.au)

Select **TOOLING**; then under Product Group **THICK TURRET**, select **WILSON STYLE**, choose your C, D & E' St Series 90 requirements listed under section **A0.3W**

Pricing and description for all shapes, rounds and accessories for Thick Turret Tooling is available at this site

# WILSON Series 90 STYLE PUSH BUTTON ADJUSTABLE GUIDE ASSEMBLY

Features Through The Tool Lubrication



(NO SHIMS REQUIRED)  
10mm Adjustment  
(For Use With Spigot Punches)  
(Will Accept Wilson Series 90 Tooling)

## 'C' Station (up to 2" or 50.8mm dia)

Complete Guide Assembly .....	AA510-000
Adjustable Punch Driver Spigot .....	AA511-000
Spigot Location Key .....	AA512-000
Punch Holding Stud .....	AA513-000
Stripper Holding Clips (ea).....	AA960-000
Stripper Holding Clip Screws (ea).....	AA961-000
T' Handle.....	AA962-000



## 'D' Station (up to 3 1/2" or 88.9mm dia)

Complete Guide Assembly .....	AA710-000
Adjustable Punch Driver Spigot .....	AA711-000
Spigot Location Key .....	AA712-000
Punch Holding Stud .....	AA713-000
Stripper Holding Clips (ea).....	AA960-000
Stripper Holding Clip Screws (ea).....	AA961-000
T' Handle.....	AA962-000

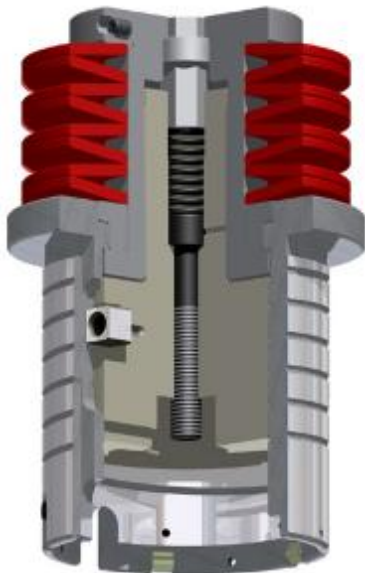

## 'E' Station (up to 4 1/2" or 114.3mm dia)

Complete Guide Assembly .....	AA910-000
Adjustable Punch Driver Spigot .....	AA911-000
Spigot Location Key .....	AA912-000
Punch Holding Stud .....	AA913-000
Stripper Holding Clips (ea).....	AA960-000
Stripper Holding Clip Screws (ea).....	AA961-000
T' Handle.....	AA962-000

For **PRICING** and extended description of the tooling on this page log on to our web site at [www.fntool.com.au](http://www.fntool.com.au)

Select **TOOLING**; then under Product Group **THICK TURRET**, select **WILSON STYLE**, choose your C, D & E' St Series 90 requirements listed under section **A0.3W**  
Pricing and description for all shapes, rounds and accessories for Thick Turret Tooling is available at this site

# WILSON Series 80 STYLE (Econoline)

**1/2" OR 'A' STATION**  
(up to 1/2" or 12.7mm dia)



## Shapes

[1] Punch & Guide Assembly .....	AW100-XXX
Punch Only.....	AW101-XXX
Guide Only .....	AW102-XXX
[3] Die.....	AA106-XXX

## Rounds

Punch & Guide Assembly .....	AW200-000
[2] Punch Only.....	AW201-000
Guide Only .....	AW202-000
Die.....	AA206-000

## Assembly Parts

Punch Head .....	AW204-000
Stripping Spring.....	AW203-000
Punch Collar (new) .....	AW205-NEW
1mm Shim Collar.....	AW205-1MM
2mm Shim Collar.....	AW205-2MM
3mm Shim Collar.....	AW205-3MM
O'Ring for Collars.....	AA215-001

Die Shims ea..... AA206-SHIM(0.5,1.0 & 1.5mm)

For **PRICING** and extended description of the tooling on this page log on to our web site at  
**[www.fmtool.com.au](http://www.fmtool.com.au)**

Select **TOOLING**; then under Product Group **THICK TURRET**, select **WILSON STYLE**, choose your A' St Series 80 requirements listed under section **A0.3W**  
Pricing and description for all shapes, rounds and accessories for Thick Turret Tooling is available at this site

**WILSON Series 80 STYLE**  
(Econoline)

**1 1/4" OR 'B' STATION**  
(up to 1 1/4" or 31.75mm dia)

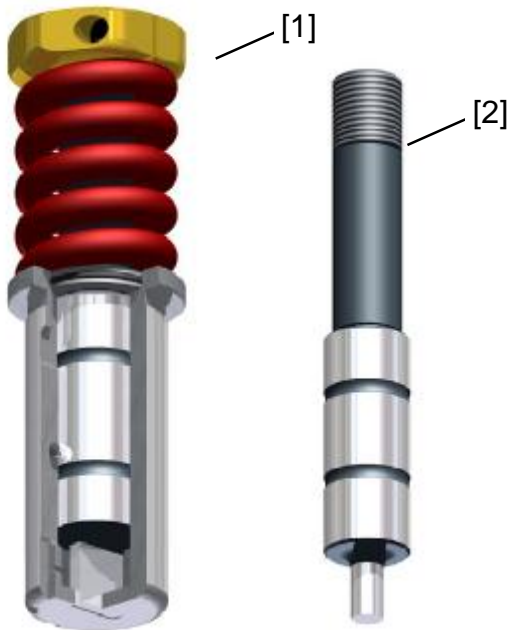

**Shapes**

[1] Punch & Guide Assembly .....	AW300-XXX
Punch Only.....	AW301-XXX
Guide Only .....	AW302-XXX
[3] Die.....	AA306-XXX

**Rounds**

Punch & Guide Assembly .....	AW400-000
[2] Punch Only.....	AW401-000
Guide Only .....	AW402-000
Die .....	AA406-000

**Assembly Parts**

Super Locking Head.....	AW414-000
Stripping Spring.....	AA403-000
0 to 3mm Punch Shim Collar .....	AW405-NEW
1 to 2mm Punch Shim Collar .....	AW405-1&2MM
O'Rings for Collars .....	AA415-001

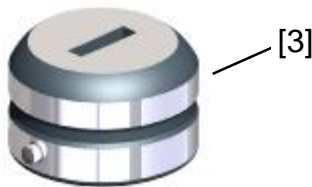

Die Shims ea.....	AA406-SHIM(0.5,1.0 & 1.5mm)
-------------------	-----------------------------

For **PRICING** and extended description of the tooling on this page log on to our web site at  
**[www.fntool.com.au](http://www.fntool.com.au)**

Select **TOOLING**; then under Product Group **THICK TURRET**, select **WILSON STYLE**, choose your B' St Series 80 requirements listed under section **A0.3W**  
Pricing and description for all shapes, rounds and accessories for Thick Turret Tooling is available at this site

# WILSON Series 80 STYLE (Econoline)

## 'C' 'D' & 'E' STATION TOOLING

For Guide Assemblies see pages  
16, 18 & 20 in Amada Section

### 2" or 'C' station (up to 2" or 50.8mm dia)

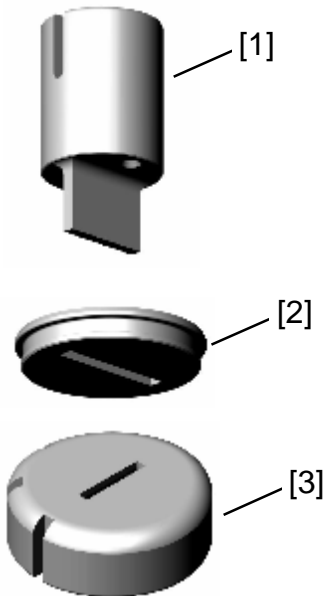

#### Shapes

Punch, Die & Stripper Set .....	AW500-XXX
[1] Punch Only .....	AA501-XXX
[2] Stripper .....	AW502-XXX
[3] Die .....	AA503-XXX

#### Rounds

Punch, Die & Stripper Set .....	AW600-000
Punch Only .....	AA601-000
Stripper .....	AW602-000
Die .....	AA603-000
Die Shims ea. ....	AA503-SHIM(0.5,1.0 & 1.5mm)

### 3½" or 'D' station (up to 3½" or 88.9mm dia)

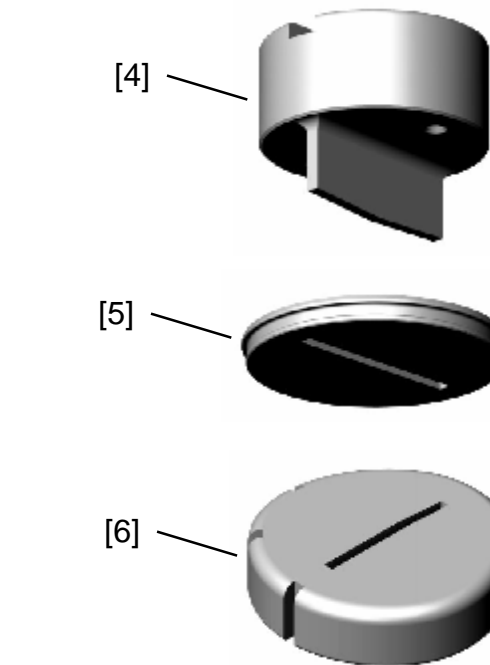

#### Shapes

Punch, Die & Stripper Set .....	AW700-XXX
[4] Punch Only .....	AA701-XXX
[5] Stripper .....	AW702-XXX
[6] Die .....	AA703-XXX

#### Rounds

Punch, Die & Stripper Set .....	AW800-000
Punch Only .....	AA801-000
Stripper .....	AW802-000
Die .....	AA803-000
Die Shims ea. ....	AA703-SHIM(0.5,1.0 & 1.5mm)

### 4½" or 'E' station (up to 4½" or 114.3mm dia)

#### Shapes

Punch, Die & Stripper Set .....	AW900-XXX
[4] Punch Only .....	AA901-XXX
[5] Stripper .....	AW902-XXX
[6] Die .....	AA903-XXX

#### Rounds

Punch, Die & Stripper Set .....	AW1000-000
Punch Only .....	AA1001-000
Stripper .....	AW1002-000
Die .....	AA1003-000
Die Shims ea. ....	AA903-SHIM(0.5,1.0 & 1.5mm)

For **PRICING** and extended description of the tooling on this page log on to our web site at

[www.fmtool.com.au](http://www.fmtool.com.au)

Select **TOOLING**; then under Product Group **THICK TURRET**, select **WILSON STYLE**, choose your C, D & E' St Series 80 requirements listed under section **A0.3W**

Pricing and description for all shapes, rounds and accessories for Thick Turret Tooling is available at this site



# MATE

## Ultra

# Style Tooling

*Manufactured by*

**F.M. TOOL & GAUGE PTY. LTD.**

A.B.N. 91 008 262 520

CUDLEE CREEK, SOUTH AUSTRALIA, 5232

PH. (08) 8389 2272 FAX. (08) 8389 2309 or (08) 8389 2478

Free Call 1800 882 993 E-mail - [sales@fmtool.com.au](mailto:sales@fmtool.com.au)

[www.fmtool.com.au](http://www.fmtool.com.au)



# MATE ULTRA STYLE

## ADJUSTABLE SPIGOT PUNCH, DIE & STRIPPER SETS

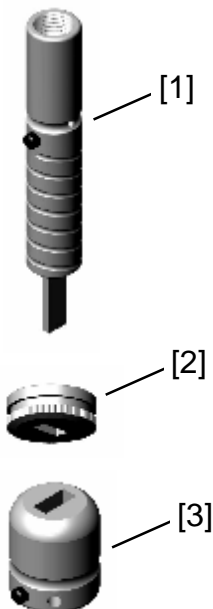

**'A' Station**  
*(Used in Mate Ultra Holders)*  
*( up to ½" or 12.7mm dia )*

### Shapes

Punch, Die & Stripper Set.....	AM180-XXX
[1] Punch only .....	AM181-XXX
[2] Stripper.....	AA185-XXX
[3] Die.....	AA106-XXX

### Rounds

Punch, Die & Stripper Set.....	AM180-000
Punch only .....	AM181-000
Stripper.....	AA185-000
Die.....	AA206-000
Die Shims ea.....	AA206-SHIM(0.5,1.0 & 1.5mm)

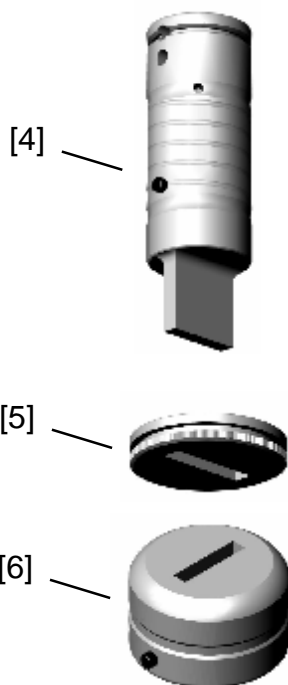

**'B' Station**  
*(Used in Mate Ultra & Euromac 4 st Multi Tool Holders)*  
*( up to 1 ¼" or 31.75mm dia )*

### Shapes

Punch, Die & Stripper Set.....	AM380-XXX
[4] Punch only .....	AM381-XXX
[5] Stripper.....	AA385-XXX
[6] Die.....	AA306-XXX

### Rounds

Punch, Die & Stripper Set.....	AM380-000
Punch only .....	AM381-000
Stripper.....	AA385-000
Die.....	AA406-000
Die Shims ea.....	AA406-SHIM(0.5,1.0 & 1.5mm)

For **PRICING** and extended description of the tooling on this page log on to our web site at  
**[www.fntool.com.au](http://www.fntool.com.au)**

Select **TOOLING**; then under Product Group **THICK TURRET**, select **MATE ULTRA STYLE**, choose your A & B' St requirements listed under section **AA0.5M & AA1.25M**  
Pricing and description for all shapes, rounds and accessories for Thick Turret Tooling is available at this site

# MATE ULTRA STYLE

## 'C' 'D' & 'E' STATION TOOLING

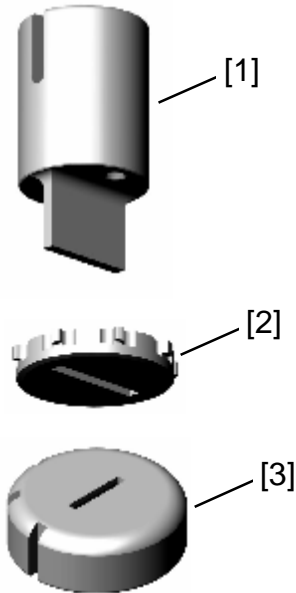

**2" or 'C' station**  
(up to 2" or 50.8mm dia)

### Shapes

Punch, Die & Stripper Set .....	AM500-XXX
[1] Punch Only .....	AA501-XXX
[2] Stripper .....	AM502-XXX
[3] Die .....	AA503-XXX

### Rounds

Punch, Die & Stripper Set .....	AM600-000
Punch Only .....	AA601-000
Stripper .....	AM602-000
Die .....	AA603-000
Die Shims ea. ....	AA503-SHIM(0.5,1.0 & 1.5mm)

---

**3½" or 'D' station**  
(up to 3½" or 88.9mm dia)

### Shapes

Punch, Die & Stripper Set .....	AM700-XXX
[4] Punch Only .....	AA701-XXX
[5] Stripper .....	AM702-XXX
[6] Die .....	AA703-XXX

### Rounds

Punch, Die & Stripper Set .....	AM800-000
Punch Only .....	AA801-000
Stripper .....	AM802-000
Die .....	AA803-000
Die Shims ea. ....	AA703-SHIM(0.5,1.0 & 1.5mm)

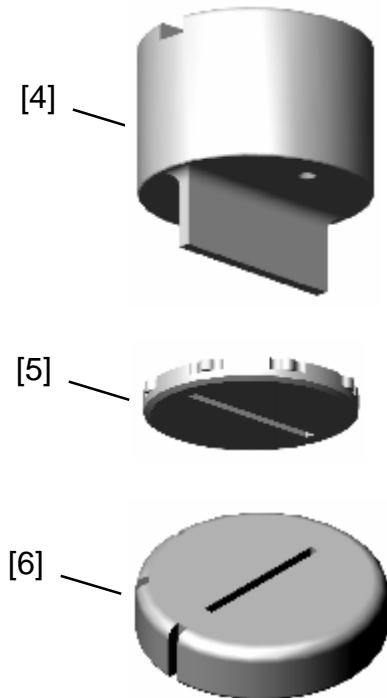

---

**4½" or 'E' station**  
(up to 4½" or 114.3mm dia)

### Shapes

Punch, Die & Stripper Set .....	AM900-XXX
[4] Punch Only .....	AA901-XXX
[5] Stripper .....	AM902-XXX
[6] Die .....	AA903-XXX

### Rounds

Punch, Die & Stripper Set .....	AM1000-000
Punch Only .....	AA1001-000
Stripper .....	AM1002-000
Die .....	AA1003-000
Die Shims ea. ....	AA903-SHIM(0.5,1.0 & 1.5mm)

For **PRICING** and extended description of the tooling on this page log on to our web site at

**[www.fmtool.com.au](http://www.fmtool.com.au)**

Select **TOOLING**; then under Product Group **THICK TURRET**, select **MATE ULTRA STYLE**, choose your C, D & E' St requirements listed under section **AA2.0M**, **AA3.5M** & **AA4.5M** Pricing and description for all shapes, rounds and accessories for Thick Turret Tooling is available at this site

# MATE/EUROMAC STYLE

# MULTI TOOLS

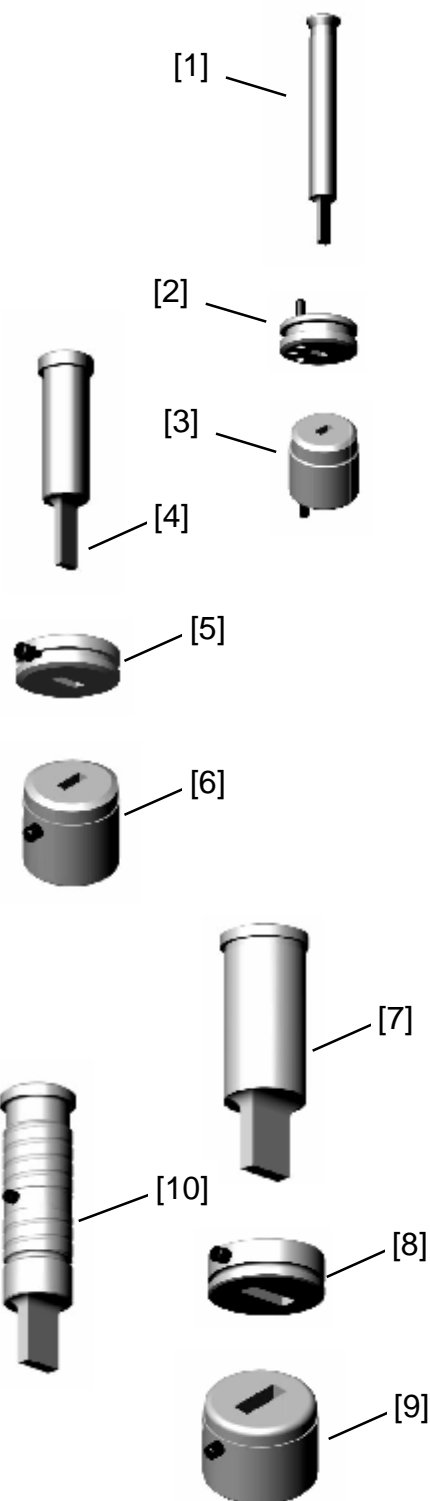

## '20 Station' (up to 8mm dia)

Shaped Punch, Die & Stripper Set.....	AMT20-0-XXX
Round Punch, Die & Stripper Set.....	AMT20-0-000
[1] Shaped Punch Only .....	AMT20-1-XXX
Round Punch Only .....	AMT20-1-000
[2] Shaped Stripper .....	AMT20-3-XXX
Round Stripper .....	AMT20-3-000
[3] Shaped Die .....	AMT20-2-XXX
Round Die .....	AMT20-2-000
Die Shims ea.....	AMT20-2-SHIM(0.5,1.0 & 1.5mm)

## '10 Station' (up to 16mm dia)

Shaped Punch, Die & Stripper Set.....	AMT10-0-XXX
Round Punch, Die & Stripper Set.....	AMT10-0-000
[4] Shaped Punch Only .....	AMT10-1-XXX
Round Punch Only .....	AMT10-1-000
[5] Shaped Stripper .....	AMT10-3-XXX
Round Stripper .....	AMT10-3-000
[6] Shaped Die .....	AMT10-2-XXX
Round Die .....	AMT10-2-000
Die Shims ea.....	AMT10-2-SHIM(0.5,1.0 & 1.5mm)

## '6 Station' (up to 24mm dia) Short Series - 70.5mm Punch

Shaped Punch, Die & Stripper Set.....	AMT8-0-XXX
Round Punch, Die & Stripper Set.....	AMT8-0-000
[7] Shaped Punch Only .....	AMT8-1-XXX
Round Punch Only .....	AMT8-1-000
[8] Shaped Stripper .....	AMT8-3-XXX
Round Stripper .....	AMT8-3-000
[9] Shaped Die .....	AMT8-2-XXX
Round Die .....	AMT8-2-000

## Long Series - 100mm Punch \*Euromac Only\*

Shaped Punch, Die & Stripper Set.....	AMT6-0-XXX
Round Punch, Die & Stripper Set.....	AMT6-0-000
[10] Shaped Punch Only .....	AMT6-1-XXX
Round Punch Only .....	AMT6-1-000
[8] Shaped Stripper .....	AMT6-3-XXX
Round Stripper .....	AMT6-3-000
[9] Shaped Die .....	AMT8-2-XXX
Round Die .....	AMT8-2-000
Die Shims ea.....	AMT8-2-SHIM(0.5,1.0 & 1.5mm)

For **PRICING** and extended description of the tooling on this page log on to our web site at

[www.fntool.com.au](http://www.fntool.com.au)

Select **TOOLING**; then under Product Group **THICK TURRET**, select **MATE ULTRA STYLE**, choose your Multi Tool requirements listed under section **AA0.1M Pricing and description for all shapes, rounds and accessories for Thick Turret Tooling is available at this site**

# Special Shapes



# Technical Information





# F.M. Tool & Gauge Pty. Ltd.

## Category 'A' Tool Selection Guide

- 000



- 100

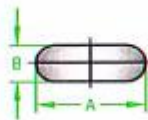

- 200



- 300

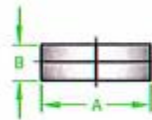

- 400

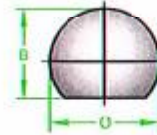

- 412

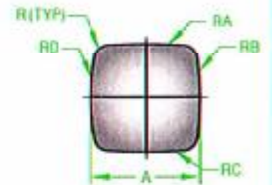

- 500

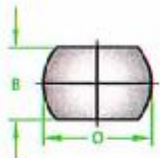

- 501

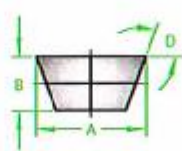

- 502

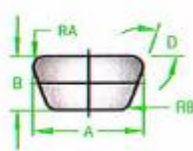

- 513

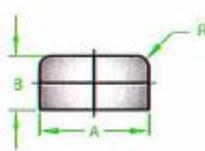

- 514

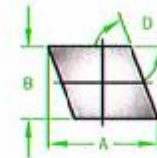

- 515

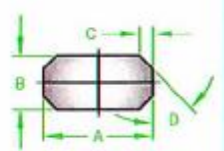

- 516

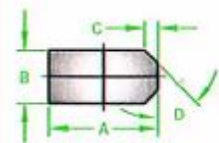

- 517



- 518

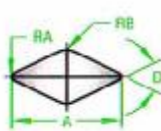

- 519

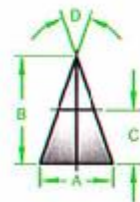

- 520

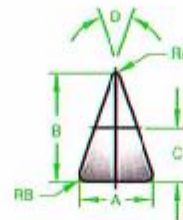

- 521

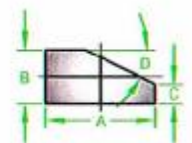

- 522

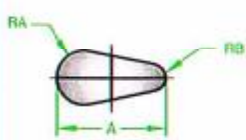

- 538

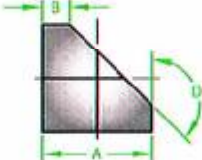

- 539

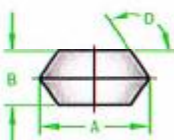

- 540

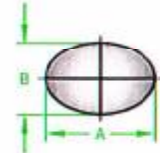

- 545

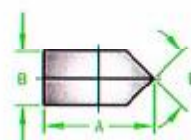

- 607

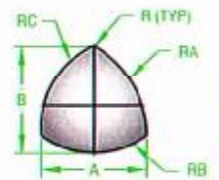

- 650

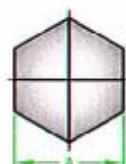

- 660

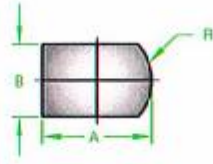

- 665

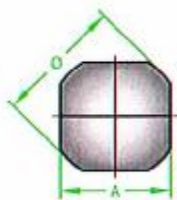

- 670



- 850

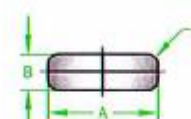

- 860

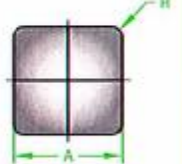



# F.M. Tool & Gauge Pty. Ltd.

## Category 'B' Tool Selection Guide

- 505

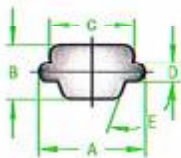

- 506

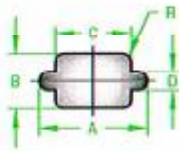

- 507

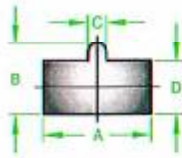

- 508

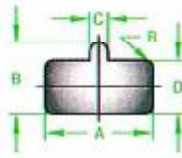

- 509

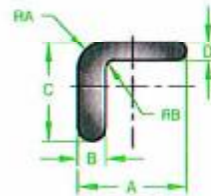

- 510

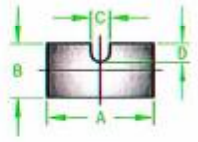

- 512

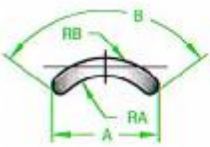

- 523



- 524

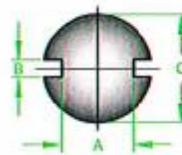

- 525

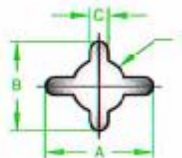

- 526

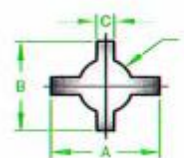

- 527

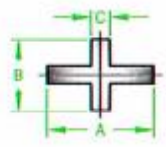

- 528

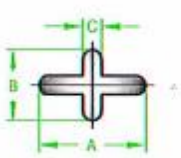

- 529

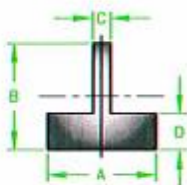

- 530

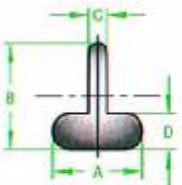

- 531

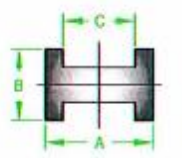

- 532

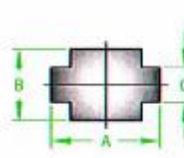

- 533

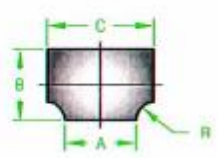

- 534

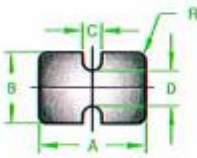

- 536

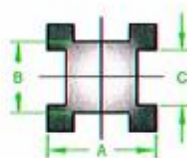

- 605

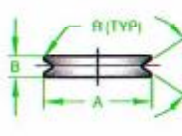

- 606

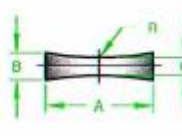

- 690

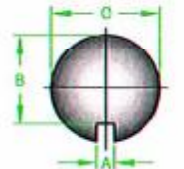

- 700

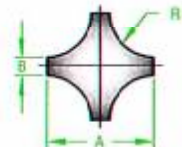

- 710

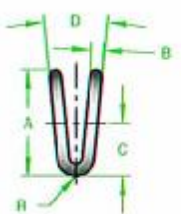

- 720

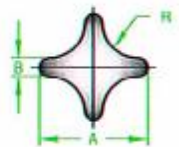

- 760



- 770

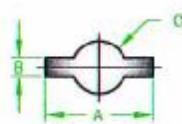

- 780

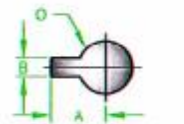

- 790

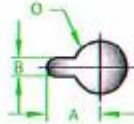



# F.M. Tool & Gauge Pty. Ltd.

## Category 'C' Tool Selection Guide

- 240

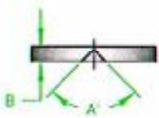

Centre Punch Up

- 241

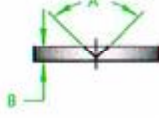

Centre Punch Down

- 541

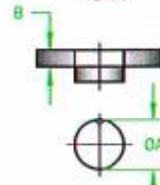

1 Tap K/Out Down

- 542

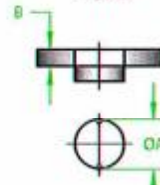

2 Tap K/Out Down

- 543

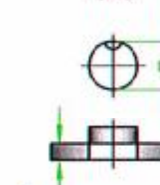

1 Tap K/Out Up

- 544

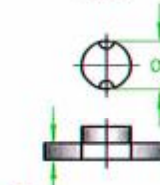

2 Tap K/Out Up

- 562

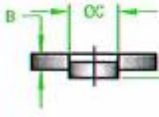

Part Shear Down

- 563

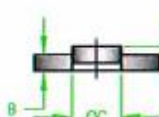

Part Shear Up

- 565

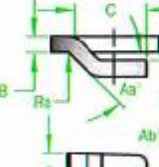

Lance & Form Down

- 566

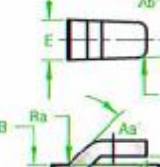

Lance & Form Up

- 577

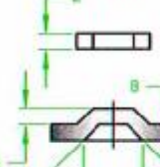

Bridge Tool Up

- 578

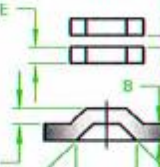

Twin Bridge Tool Up

- 645

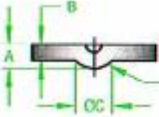

Dimple Down

- 646

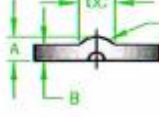

Dimple Up

- 653

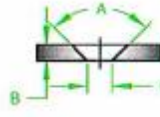

Coined C/Sink Down

- 654

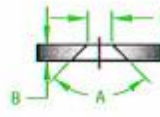

Coined C/Sink Up

- 655

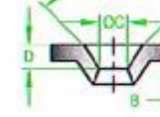

Formed C/Sink Down

- 656

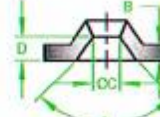

Formed C/Sink Up

- 675

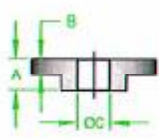

Extrusion Down

- 676

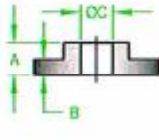

Extrusion Up

- 755

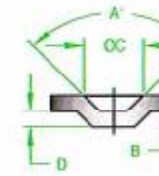

Emboss Down

- 756

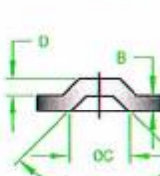

Emboss Up

- 757

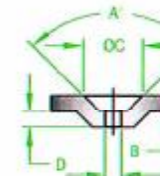

Pierced Emboss Down

- 758

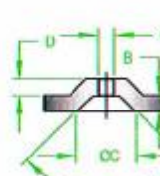

Pierced Emboss Up

- 775

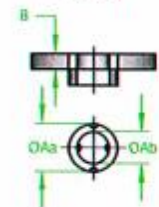

Double K/Out Down

- 776

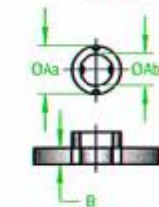

Double K/Out Up

- 812

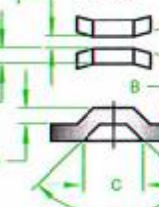

Card Holder Tool Up

- 910

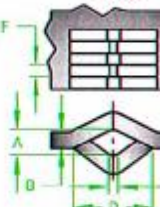

Edge Fix Tool

- 920

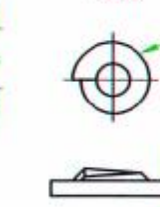

Thread Form

\*A = Thread Form & Pitch





# F.M. Tool & Gauge Pty. Ltd.

## Category 'C' Tool Selection Guide

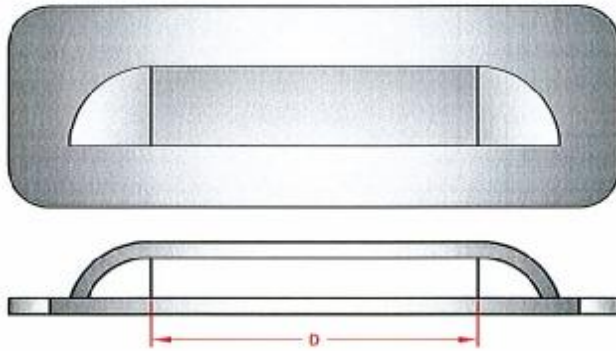

Louvre Tool Up  
-999

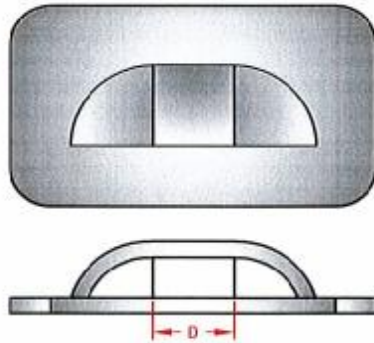
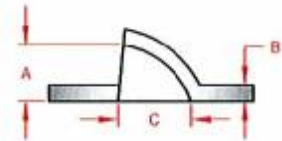

Nibble Louvre Tool Up  
-995

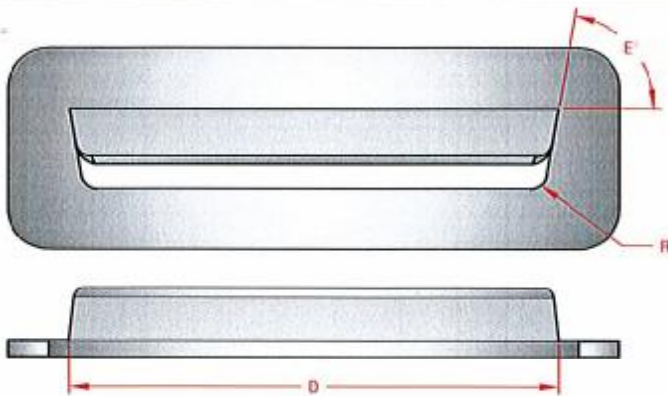
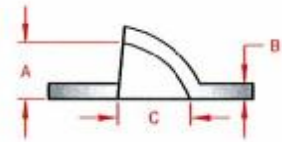

Air Louvre Tool Up  
-997

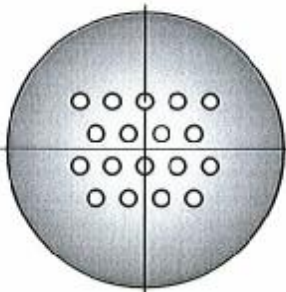
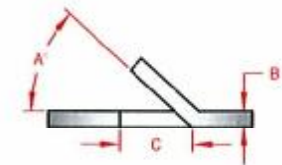

Pin Hole Cluster

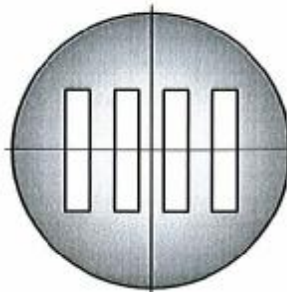

Shaped Cluster

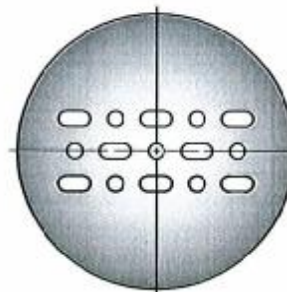

Multi Shaped Cluster



Special Shaped Cluster

## Material Multiplication Factor (F)

Material Description	Multiplier (F)	Material Description	Multiplier (F)
Aluminium - Soft Sheet	0.30	Steel - Mila	1.00
Aluminium - Half Hara	0.38	Steel - ASTM-A36	1.20
Aluminium - Hara	0.50	Steel - 50 Carbon	1.40
Brass - Soft Sheet	0.60	Steel - Cold Drawn	1.20
Brass - Half Hara	0.70	Steel - Stainless	1.40
Copper - Rolled	0.57	Spring Steel (Tempered)	4.00

Based on Mild Steel Shear Strength of 50,000 P.S.I (345 MPa)

## Total Cutting Edge

In order to calculate the tonnage required to cut out a shape, it is necessary to work out the total length of the cutting edge, ("L").

ie. The perimeter of the shape to be cut.

**Example:**

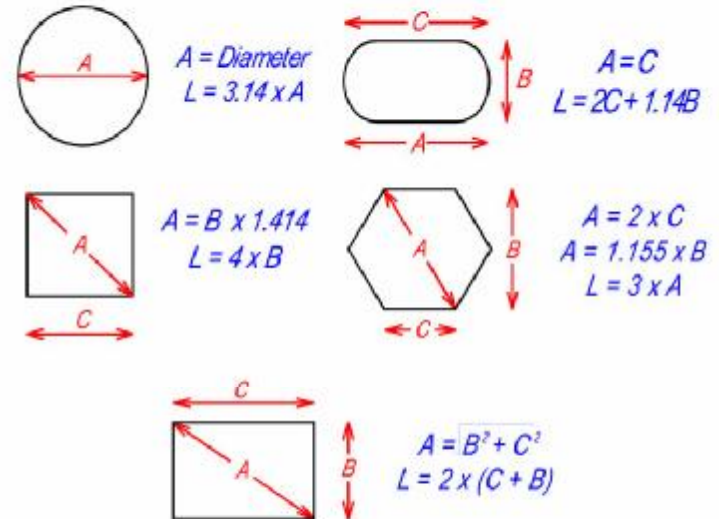

## Tonnage Calculation

The tonnage required for punching any shape hole in a material is given by the following formula:

Required Tonnage =  $L \times G \times S$  where:-

"L" is the total length of the cutting edge

"G" is the material thickness

"S" is the shear strength of the material

Hence required tonnage.

**Example 1:** For a 50mm square in 2mm mild steel

$$L = 50 \times 4 = 200 \quad G = 2 \quad \& \quad S = 0.345$$

Hence required tonnage.

$$T = 200 \times 2 \times 0.345 = 137.95 \text{ KN}$$

### Punches with Shear

The tonnage required for punching with shear is given by the formula:-  $T = L \times G \times S \times F$

Where "F" is the shear factor (see 'Calculating the effect of shear')

**Example 2:** For a 3/8" x 3" Slitting Tool with 3/16" Shear Cutting 1/4" Hard Aluminium

$$F = 0.63 \text{ (from graph below)}$$

$$L = 2 (3/8 \times 3) = 2.25 \quad G = 0.25 \quad S = 12 \quad F = 0.63$$

Hence required tonnage:

$$T = 2.25 \times 0.25 \times 12 \times 0.63 = 4.25 \text{ ton}$$

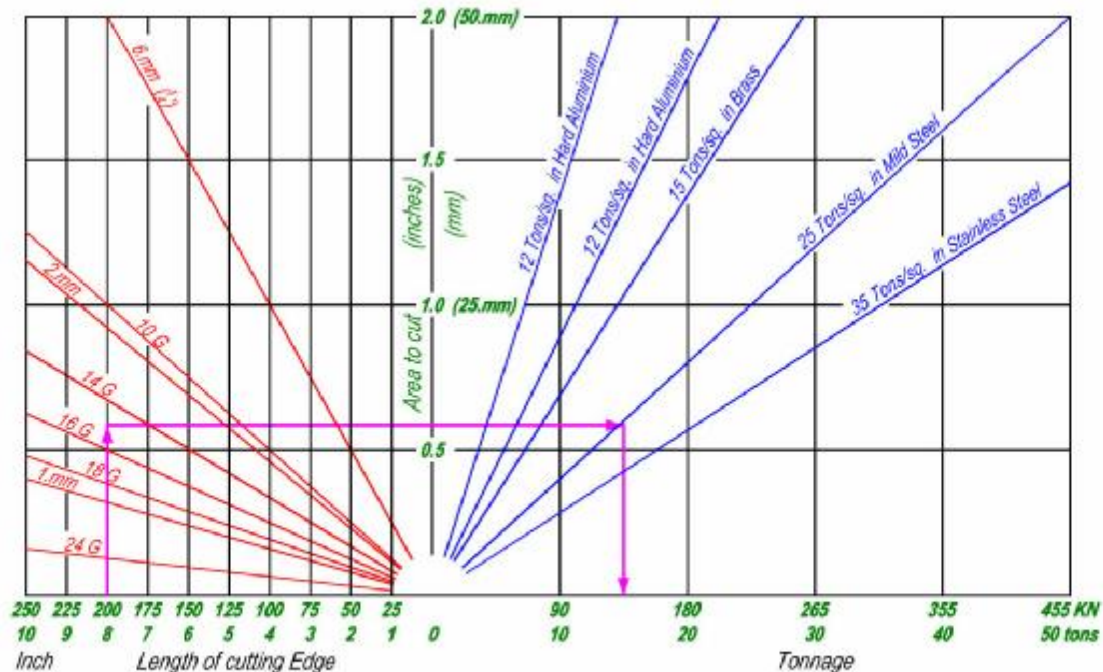

# Recommended Clearances

Total Clearance Calculated

Material	% of Material Thickness	Material Thickness					
		20G 0.9	18G 1.2	16G 1.6	14G 2.0	10G 3.0	¼" 6.0
Aluminium	15%	0.14	0.18	0.24	0.3	0.45	0.9
Mild Steel	20%	0.18	0.24	0.32	0.4	0.6	1.2
Stainless Steel	25%	0.23	0.3	0.4	0.5	0.75	1.5

Please Note Measurements in mm

This is a recommended guide. If any problems or queries arise please contact F.M. Tool & Gauge for our expert advice.

Shear is used on punches to reduce tonnage and noise whilst punching.  
A full shear can reduce the tonnages by up to 50%.

### Rooftop Shear:

- Ideal when punching at high loads
- Avoid excessive side loading by Taking large cuts (over 75%)



### Inverted Rooftop:

- Very effective
- Easy to produce and regrind
- Avoid sharp corner in the centre, as this provides a stress point, making the tool more susceptible

### Concave:

- Best for nibbling
- More difficult to regrind Than inverted rooftop

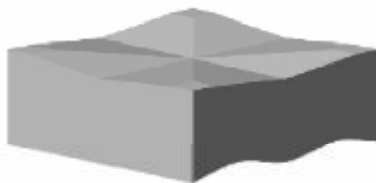

### Four Way Shear:

- Ideal for large squares
- always avoid sharp inside corners, as these encourage breakage

## Calculating The Effect Of Shear

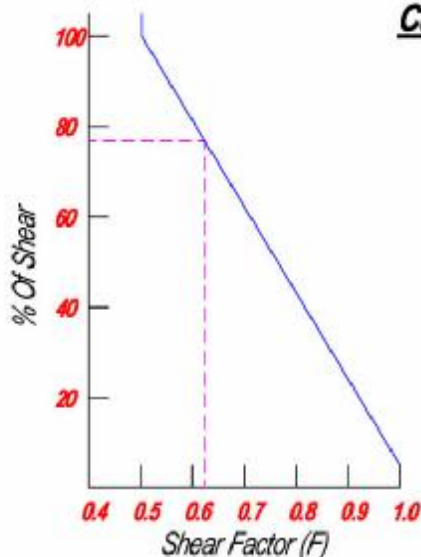

$$\text{Shear Factor (F)} = \frac{104 - (\text{Shear \%} \times 0.54)}{100}$$

eg. 75% Shear = 0.63  
Shear Factor

$$\% \text{ Of Shear} = \frac{\text{Shear Depth} \times 100}{\text{Material Thickness}}$$

eg. ¼" Material with  
3/16" shear on tool

$$= \frac{0.1875 \times 100}{0.250}$$

$$= 75\%$$

## *“Handy Hints on Ordering”*

- ◆ *When placing orders please give as much information as possible. The greater the information given, the less likely there is of a mistake or problem occurring with the order. (we will query you if we see a possible problem)*
- ◆ *All relevant dimensions are required. A very common problem can occur when requesting a round ended shape. **Eg: 15 x 12mm**. This can mean 1 of several shapes. (see example below)*
- ◆ *Using part numbers helps to eliminate misunderstandings.*
- ◆ *We suggest you advise material and gauge being punched.*
- ◆ *Show keyways and centre lines on special shapes.*
- ◆ *Standard practise is to put clearance on the die. Punch size will give you hole size and die size will give you slug size. (if you require the slug please advise)*
- ◆ *Solid or re-inforced dies can be supplied on request.*
- ◆ *On special shapes we recommend rads on any sharp corner, this will give added strength to your tool.*
- ◆ **TROUBLESHOOTING:-** *for problems such as slug pull please ring and ask, as each situation is different. **Good advise is cheap.***
- ◆ **Don't forget**—*it is extremely easy to place orders direct from the internet—just remember [www.fmtool.com.au](http://www.fmtool.com.au)*  
*Please Note: First time users need to be registered with a password*

**Example:** (from above)

**12 x 15 Oblong**

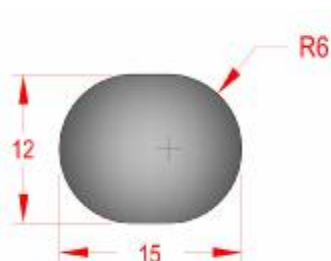

**12 x 15 Double Dee**

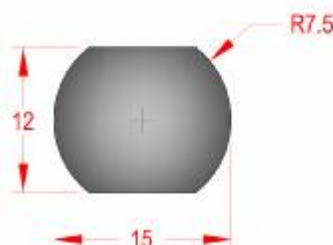

**12 x 15 x R9 Doorlock**

